

TWO PIECE FULL BORE BALL VALVE NPT

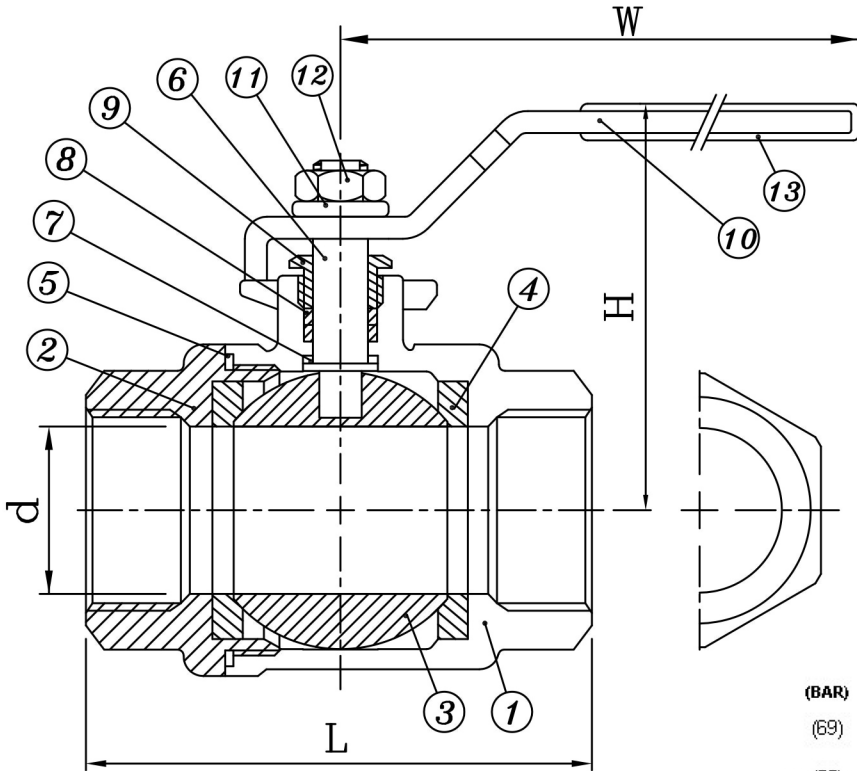
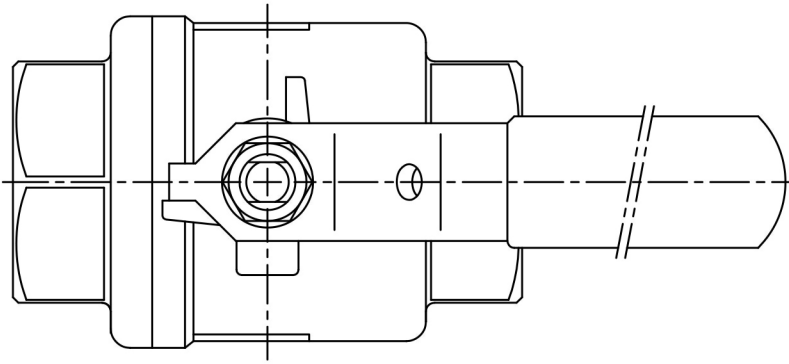

ITEM	PARTS	Q.TY	MATERIAL
1	BODY	1	CF8M 316
2	CAP	1	CF8M 316
3	BALL	1	CF8M 316
4	BALL SEAT	2	PTFE
5	JOINT GASKET	1	PTFE
6	STEM	1	AISI 304
7	THRUST WASHER	1	PTFE
8	STEM PACKING	2	PTFE
9	GLAND NUT	1	AISI 304
10	HANDLE	1	AISI 304
11	SPRING WASHER	1	AISI 304
12	STEM NUT	1	AISI 304
13	PLASTIC COVER	1	PLASTIC

Size: 1/4"-2"
 Full bore
 Threaded ends: ANSI B2.1 NPT
 Quality investment casting body and cap
 Internal entry blow-out proof stem
 Material: CF8M 316
 Pressure rating 1000PSI(WOG)
 Pressure test: API 598

PRESSURE TEMPERATURE RATINGS

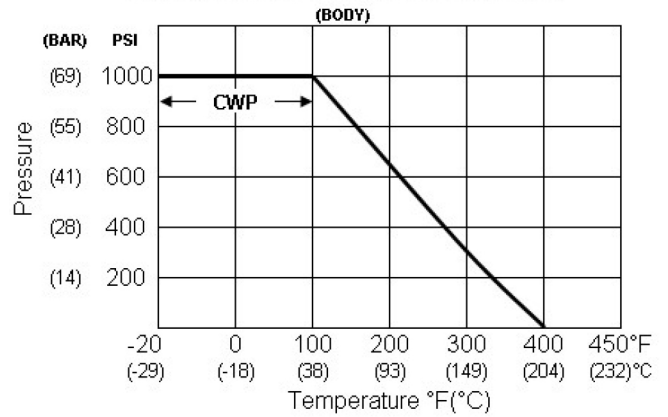

SIZE NPT	PART No	D	L	H	W	CV FACTOR	Kg
1/4	FBV04N	11.6	48	48	100	6	0.18
3/8	FBV06N	11.6	48	48	100	7	0.19
1/2	FBV08N	15	58	52	100	10	0.26
3/4	FBV12N	20	65.7	61	127	25	0.4
1	FBV16N	25	77	65	127	35	0.59
1 1/4	FBV20N	32	90	79	154	46	1.0
1 1/2	FBV24N	38	98	83	154	80	1.32
2	FBV32N	50	121	97	192	110	2.46

DIMENSIONS SUBJECT TO CHANGE, PLEASE CONTACT US IF CRITICAL