



Instrumentation Solutions

Pipe Fittings

www.fd-lok.com



ZHEJIANG FANGDUN INSTRUMENT VALVE CO.,LTD
No.177, Zhanwang Road, Longwan Industry Center,
Wenzhou, Zhejiang, China 325024

Tel: 86-577-8692 7952
Fax: 86-577-8598 9788
E-mail: fangdun@fd-lok.com

ZHEJIANG FANGDUN INSTRUMENT VALVE CO.,LTD

Contents

03 Pipe Plugs

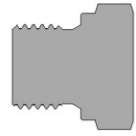

04 Hollow Hex Plugs

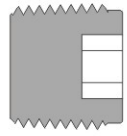

05 Close Nipples



05 Special Pipe Nipples



06 Hex Nipples

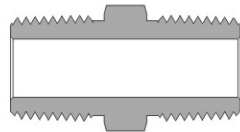

09 Hex Long Nipples



10 Reducing Bushings

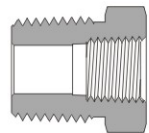

12 Pipe Caps

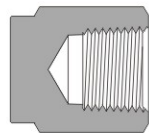

13 Hex Couplings

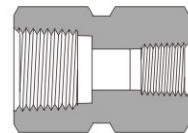

14 Union Ball Joints

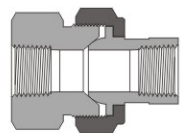

15 Adapters

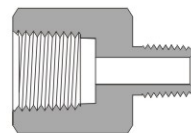

16 Male Elbows

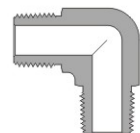

18 Street Elbows

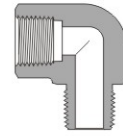

20 45° Street Elbows

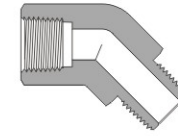

22 Female Elbows

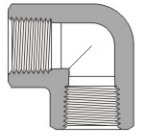

23 45° Female Elbows

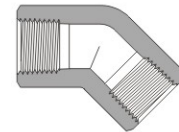

24 Male Tees

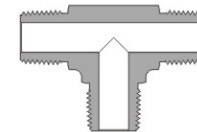

25 Female Branch Tees

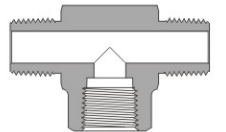

25 Female Run Tees

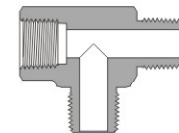

26 Male Street Tees

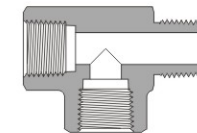

27 Male Branch Tees

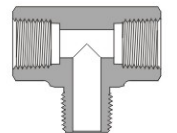

28 Female Tees

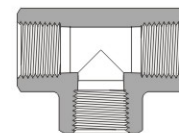

29 Female Crosses

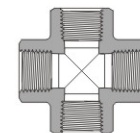

29 Pipe to Pipe Unions

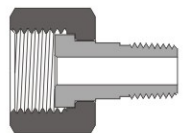

Contents

30 Hand Tight Adapter Fittings

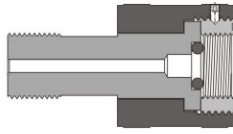

31 Ordering Information

Features

- The hardened threads with smooth surface finishing avoid galling and help to extend the fitting service life.
- Radius junction design with elbows provides smooth flow path.
- Every fitting is stamped with size, material, and heat code.

Technical Data

- Sizes range from 1/16 to 2
- Thread Specifications:

Thread Type	Specification
NPT	ASME B1.20.1, SAE AS71051
ISO Tapered	ISO 7-1, BS 21, JIS B0203
ISO Parallel	ISO 228, JIS B0202
SAE/MS	ASME B1.1, SAE J475
Metric	ISO 261

- Working temperatures:
For the working temperatures of FD-LOK pipe fittings, refer to the FD-LOK Tube Fittings catalog.
- Working Pressure:
1. Catalog working pressures shown are based on ANTI/ASME B31.3 at ambient temperature, to determine working pressures in accordance with ANSI/ASME B31.1 multiply catalog working pressures shown by the factor from the below table.

Material	Factor
Stainless steel	0.94
Carbon steel	0.85
Brass	1.0

2. Use the allowable working pressure at ambient temperature to multiply the elevated temperature factors to get the working pressure at elevated temperature. To know the elevated temperature factor, please refer to the related information of FD-LOK Tube Fittings in page 9.
3. To get the installation torque for NPT thread and ISO tapered thread, refer to FD-LOK Tube Fittings in page 1.

Material

Material	Bar Stock	Forging	Designator
316 stainless steel	ASTM A276, ASME SA479, EN 1.4401	ASTM A182, ASME SA182, EN 1.4401	SS
304 stainless steel	ASTM A276, ASME SA479, EN 1.4301	ASTM A182, ASME SA182, EN 1.4301	S4
Alloy 400/R-405	ASTM B164, ASME SB164	ASTM B564 ASME SB564	M
Alloy 600	ASTM B166, ASME SB166	ASTM B564, ASME SB564	INC
Alloy C-276	ASTM B574	ASTM B564,	HC
Brass	ASME B16/ASTM B453	ASTM B283	B
Carbon steel	ASTM A108	ASTM A105	CS
904L stainless steel	ASTM B649	ASTM A182	904L

Cautions:

- Do not loosen or tighten fittings when system is pressurized.
- Always use proper thread sealants on tapered pipe threads.
- Confirm the sealing type when choosing the straight threads, make sure the construction of the matching threads comply with the sealing type.

Pipe Plugs

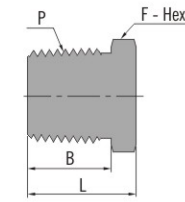

Male NPT Threads

P-NPT Size	Basic Ordering Number	Dimension, mm		
		L	F	B
1/16	-PP-NT1	14.2	7.9	9.7
1/8	-PP-NT2	14.2	11.1	9.7
1/4	-PP-NT4	19.1	14.3	14.2
3/8	-PP-NT6	19.8	17.5	14.2
1/2	-PP-NT8	24.6	22.2	19.1
3/4	-PP-NT12	30.7	27.0	19.1
1	-PP-NT16	38.1	34.9	23.9
1 1/4	-PP-NT20	38.4	44.5	23.9
1 1/2	-PP-NT24	43.7	50.8	26.2
2	-PP-NT32	50.8	69.9	26.2

Male ISO Tapered Threads

P-RT Size	Basic Ordering Number	Dimension, mm		
		L	F	B
1/16	-PP-RT1	14.2	7.9	9.7
1/8	-PP-RT2	14.2	11.1	9.7
1/4	-PP-RT4	19.1	14.3	14.2
3/8	-PP-RT6	19.8	17.5	14.2
1/2	-PP-RT8	24.6	22.2	19.1
3/4	-PP-RT12	30.7	27.0	19.1
1	-PP-RT16	38.1	34.9	23.9
1 1/4	-PP-RT20	38.4	44.5	23.9
1 1/2	-PP-RT24	43.7	50.8	26.2
2	-PP-RT32	50.8	69.9	26.2

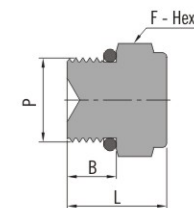

Male SAE/MS Straight Threads

P-SAE/MS Thread Size	Basic Ordering Number	Dimension, mm		
		L	F	B
7/16-20	-PP-ST7	19.3	14.3	9.1
9/16-18	-PP-ST9	20.8	17.5	9.9
3/4-16	-PP-ST12	22.6	22.2	11.2
1 1/16-12	-PP-ST17	28.4	31.8	15.0
1 5/16-12	-PP-ST21	30.0	38.1	15.0

Dimensions are for reference only, subject to change.

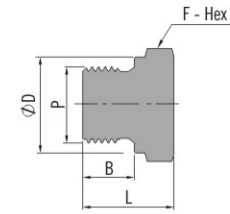

Male ISO Parallel Threads

P-RS Size	Basic Ordering Number	Dimension, mm			
		L	F	B	D
1/8	-PP-RS2	14.0	14.3	7.1	13.7
1/4	-PP-RS4	19.8	19.1	11.2	18.0
3/8	-PP-RS6	19.8	22.2	11.2	21.8
1/2	-PP-RS8	25.1	27.0	14.0	25.9
3/4	-PP-RS12	28.7	33.3	15.7	32.0
1	-PP-RS16	30.7	41.3	18.0	39.1

Male Metric Threads

P-Metric Size	Basic Ordering Number	Dimension, mm			
		L	F	B	D
M14 x 1.5	-PP-MRS14	21.0	20.6	12	18.8
M16 x 1.5	-PP-MRS16	23.0	22.2	12	20.8
M18 x 1.5	-PP-MRS18	25.0	23.8	12	22.8
M20 x 1.5	-PP-MRS20	26.5	25.4	14	24.8
M22 x 1.5	-PP-MRS22	28.5	28.6	14	26.8
M24 x 1.5	-PP-MRS24	29.0	35.0	14	28.8
M27 x 2	-PP-MRS27	30.0	36.5	16	31.8

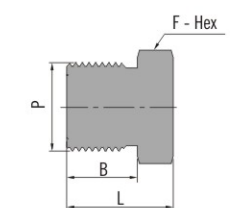

Male Metric Threads

P-Metric Size	Basic Ordering Number	Dimension, mm		
		L	F	B
M14 x 1.5	-PP-MM14	18	16	13
M16 x 1.5	-PP-MM16	20	18	14
M18 x 1.5	-PP-MM18	22	19	15
M20 x 1.5	-PP-MM20	24	22	16
M22 x 1.5	-PP-MM22	26	24	17
M24 x 1.5	-PP-MM24	26	27	17
M27 x 2	-PP-MM27	27	30	18
M30 x 2	-PP-MM30	32	32	20

Hollow Hex Plugs

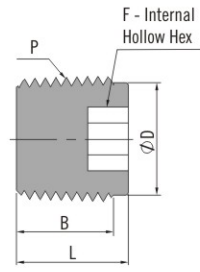

Male NPT Threads

P-NPT Size	Basic Ordering Number	Dimension, mm			
		L	F	B	D
1/16	-PI-NT1	7.6	4.0	7.4	7.4
1/8	-PI-NT2	10.4	4.8	7.4	9.4
1/4	-PI-NT4	15.5	6.4	12.4	12.1
3/8	-PI-NT6	15.0	7.9	11.9	15.7
1/2	-PI-NT8	19.3	9.5	16.2	19.3
3/4	-PI-NT12	19.8	14.3	16.7	25.7
1	-PI-NT16	20.8	15.9	17.7	31.8

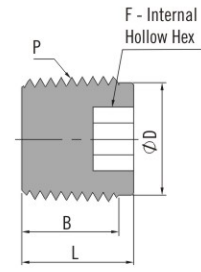

Male ISO Tapered Threads

P-RT Size	Basic Ordering Number	Dimension, mm			
		L	F	B	D
1/16	-PI-RT1	7.6	4.0	7.4	7.4
1/8	-PI-RT2	10.4	4.8	7.4	9.4
1/4	-PI-RT4	15.5	6.4	12.4	12.1
3/8	-PI-RT6	15.5	7.9	12.4	15.7
1/2	-PI-RT8	19.3	9.5	16.2	19.3
3/4	-PI-RT12	19.8	14.3	16.7	25.7
1	-PI-RT16	20.8	15.9	17.7	31.8

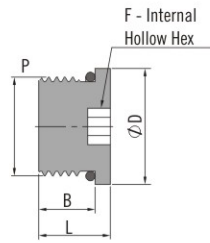

Male SAE/MS Straight Threads

P-SAE/MS Thread Size	Basic Ordering Number	Dimension, mm			
		L	F	B	D
7/16-20	-PI-ST7	11.4	4.8	9.1	14.2
9/16-18	-PI-ST9	12.2	6.4	9.9	17.5
3/4-16	-PI-ST12	14.2	7.9	11.2	22.4
1 1/16-12	-PI-ST17	19.1	14.3	15.0	31.8
1 5/16-12	-PI-ST21	19.1	15.9	15.0	38.1

Close Nipples

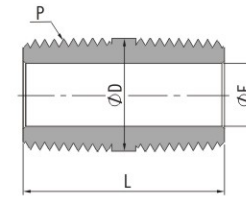

Male NPT Threads

P-NPT Size	Basic Ordering Number	Dimension, mm			Working Pressure psig (bar)	
		L	D	E	316 SS, Steel	Brass
1/16	-PCN-NT1	19.1	7.9	3.0	11000 (757)	5500 (378)
1/8	-PCN-NT2	19.1	10.3	4.8	10000 (689)	5000 (344)
1/4	-PCN-NT4	28.4	13.7	7.1	8000 (551)	4000 (275)
3/8	-PCN-NT6	28.4	17.1	9.6	7800 (537)	3900 (268)
1/2	-PCN-NT8	38.1	21.3	11.9	7700 (530)	3800 (261)
3/4	-PCN-NT12	38.1	26.7	15.7	7300 (502)	3600 (248)
1	-PCN-NT16	47.8	33.4	22.4	5300 (365)	2600 (179)

Male ISO Tapered Threads

P-RT Size	Basic Ordering Number	Dimension, mm			Working Pressure psig (bar)	
		L	D	E	316 SS, Steel	Brass
1/16	-PCN-RT1	19.1	7.9	3.0	11000 (757)	5500 (378)
1/8	-PCN-RT2	19.1	10.3	4.8	10000 (689)	5000 (344)
1/4	-PCN-RT4	28.4	13.7	7.1	8000 (551)	4000 (275)
3/8	-PCN-RT6	28.4	17.1	9.7	7800 (537)	3900 (268)
1/2	-PCN-RT8	38.1	21.3	11.9	7700 (530)	3800 (261)
3/4	-PCN-RT12	38.1	26.7	15.7	7300 (502)	3600 (248)
1	-PCN-RT16	47.8	33.4	22.4	5300 (365)	2600 (179)

Special Pipe Nipples

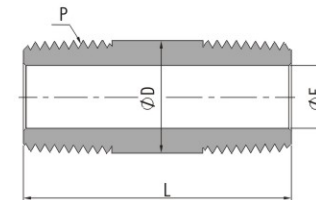

Male NPT Threads

P-NPT Size	Basic Ordering Number	Dimension, mm			Working Pressure psig (bar)	
		L	D	E	316 SS, Steel	Brass
1/8	-PSN-NT2-38.1	38.1	10.3	4.8	10000 (689)	5000 (344)
1/8	-PSN-NT2-50.8	50.8	10.3	4.8	10000 (689)	5000 (344)
1/8	-PSN-NT2-63.5	63.5	10.3	4.8	10000 (689)	5000 (344)
1/8	-PSN-NT2-76.2	76.2	10.3	4.8	10000 (689)	5000 (344)
1/4	-PSN-NT4-38.1	38.1	13.7	7.1	8000 (551)	4000 (275)
1/4	-PSN-NT4-50.8	50.8	13.7	7.1	8000 (551)	4000 (275)
1/4	-PSN-NT4-63.5	63.5	13.7	7.1	8000 (551)	4000 (275)
1/4	-PSN-NT4-76.2	76.2	13.7	7.1	8000 (551)	4000 (275)
1/4	-PSN-NT4-101.6	101.6	13.7	7.1	8000 (551)	4000 (275)
3/8	-PSN-NT6-38.1	38.1	17.1	9.7	7800 (537)	3900 (268)
3/8	-PSN-NT6-50.8	50.8	17.1	9.7	7800 (537)	3900 (268)
3/8	-PSN-NT6-63.5	63.5	17.1	9.7	7800 (537)	3900 (268)
3/8	-PSN-NT6-76.2	76.2	17.1	9.7	7800 (537)	3900 (268)
3/8	-PSN-NT6-101.6	101.6	17.1	9.7	7800 (537)	3900 (268)
1/2	-PSN-NT8-50.8	50.8	21.3	11.9	7700 (530)	3800 (261)
1/2	-PSN-NT8-76.2	76.2	21.3	11.9	7700 (530)	3800 (261)
1/2	-PSN-NT8-101.6	101.6	21.3	11.9	7700 (530)	3800 (261)
1/2	-PSN-NT8-152.4	152.4	21.3	11.9	7700 (530)	3800 (261)
3/4	-PSN-NT12-50.8	50.8	26.7	15.7	7300 (502)	3600 (248)
3/4	-PSN-NT12-76.2	76.2	26.7	15.7	7300 (502)	3600 (248)
3/4	-PSN-NT12-101.6	101.6	26.7	15.7	7300 (502)	3600 (248)
1	-PSN-NT16-76.2	76.2	33.4	22.4	5300 (365)	2600 (179)
1	-PSN-NT16-101.6	101.6	33.4	22.4	5300 (365)	2600 (179)

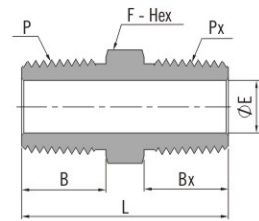

Male NPT Threads

P-NPT Size	Px-NPT Size	Basic Ordering Number	Dimension, mm					Working Pressure psig (bar)	
			L	F	B	Bx	E	316 SS, Steel	Brass
1/16	1/16	-PHN-NT1	25.6	7.9	9.7	9.7	3.0	11000 (757)	5500 (378)
1/8	1/16	-PHN-NT2-NT1	25.6	11.1	9.7	9.7	3.0	11000 (757)	5500 (378)
1/8	1/8	-PHN-NT2	25.6	11.1	9.7	9.7	4.8	10000 (689)	5000 (344)
1/4	1/16	-PHN-NT4-NT1	31.0	14.3	14.2	9.7	3.0	11000 (757)	5500 (378)
1/4	1/8	-PHN-NT4-NT2	31.0	14.3	14.2	9.7	4.8	10000 (689)	5000 (344)
1/4	1/4	-PHN-NT4	35.6	14.3	14.2	14.2	7.1	8000 (551)	4000 (275)
3/8	1/16	-PHN-NT6-NT1	31.8	17.5	14.2	9.7	3.0	11000 (757)	5500 (378)
3/8	1/8	-PHN-NT6-NT2	31.8	17.5	14.2	9.7	4.8	10000 (689)	5000 (344)
3/8	1/4	-PHN-NT6-NT4	36.3	17.5	14.2	14.2	7.1	8000 (551)	4000 (275)
3/8	3/8	-PHN-NT6	36.3	17.5	14.2	14.2	9.7	7800 (537)	3900 (268)
1/2	1/8	-PHN-NT8-NT2	37.3	22.2	19.1	9.7	4.8	7700 (530)	3800 (261)
1/2	1/4	-PHN-NT8-NT4	41.9	22.2	19.1	14.2	7.1	8000 (551)	4000 (275)
1/2	3/8	-PHN-NT8-NT6	41.9	22.2	19.1	14.2	9.7	7800 (537)	3900 (268)
1/2	1/2	-PHN-NT8	46.7	22.2	19.1	19.1	11.9	7700 (530)	3800 (261)
3/4	1/8	-PHN-NT12-NT2	40.4	27.0	19.1	9.7	4.8	10000 (689)	5000 (344)
3/4	1/4	-PHN-NT12-NT4	41.9	27.0	19.1	14.2	7.1	8000 (551)	4000 (275)
3/4	3/8	-PHN-NT12-NT6	45.2	27.0	19.1	14.2	9.7	7800 (537)	3900 (268)
3/4	1/2	-PHN-NT12-NT8	46.7	27.0	19.1	19.1	11.9	7700 (530)	3800 (261)
3/4	3/4	-PHN-NT12	46.7	27.0	19.1	19.1	15.7	7300 (502)	3600 (248)
1	1/8	-PHN-NT16-NT2	45.2	34.9	23.9	9.7	4.8	10000 (689)	5000 (344)
1	1/4	-PHN-NT16-NT4	49.3	34.9	23.9	14.2	7.1	5300 (365)	2600 (179)
1	3/8	-PHN-NT16-NT6	50.0	34.9	23.9	14.2	9.7	7800 (537)	3900 (268)
1	1/2	-PHN-NT16-NT8	54.1	34.9	23.9	19.1	11.9	7700 (530)	3800 (261)
1	3/4	-PHN-NT16-NT12	54.1	34.9	23.9	19.1	15.7	7300 (502)	3600 (248)
1	1	-PHN-NT16	58.9	34.9	23.9	23.9	22.4	5300 (365)	2600 (179)
1 1/4	1	-PHN-NT20-NT16	62.2	44.5	23.9	23.9	22.4	5300 (365)	2600 (179)
1 1/4	1 1/4	-PHN-NT20	62.9	44.5	23.9	23.9	28.6	6000 (410)	3000 (200)
1 1/2	1 1/2	-PHN-NT24	66.3	50.8	26.2	26.2	34.0	5000 (344)	2500 (172)
2	2	-PHN-NT32	77.7	69.9	26.2	26.2	45.0	3900 (268)	1900 (130)
Heavy-Wall Male NPT Threads									
1/4	1/4	-PHN-NT4-10K	35.6	14.3	14.2	14.2	5.8	10000(689)	/
1/2	1/4	-PHN-NT8-NT4-10K	41.9	22.2	19.1	14.2	5.8	10000(689)	/
1/2	1/2	-PHN-NT8-10K	46.7	22.2	19.1	19.1	9.9	10000(689)	/

Male ISO Tapered Threads

P-RT Size	Px-RT Size	Basic Ordering Number	Dimension, mm					Working Pressure psig (bar)	
			L	F	B	Bx	E	316 SS, Steel	Brass
1/8	1/8	-PHN-RT2	25.6	11.1	9.7	9.7	4.8	10000 (689)	5000 (344)
1/4	1/4	-PHN-RT4	35.6	14.3	14.2	14.2	7.1	8000 (551)	4000 (275)
3/8	3/8	-PHN-RT6	36.3	17.5	14.2	14.2	9.7	7800 (537)	3900 (268)
1/2	1/2	-PHN-RT8	46.7	22.2	19.1	19.1	11.9	7700 (530)	3800 (261)
3/4	3/4	-PHN-RT12	46.7	27.0	19.1	19.1	15.7	7300 (502)	3600 (248)
1	1	-PHN-RT16	58.9	34.9	23.9	23.9	22.4	5300 (365)	2600 (179)

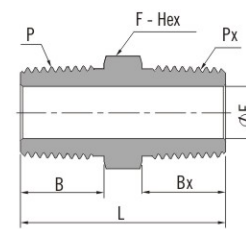

Male NPT Threads

P-NPT Size	Px-RT Size	Basic Ordering Number	Dimension, mm					Working Pressure psig (bar)	
			L	F	B	Bx	E	316 SS, Steel	Brass
1/8	1/8	-PHN-NT2-RT2	25.6	11.1	9.7	9.7	4.8	10000 (689)	5000 (344)
1/4	1/4	-PHN-NT4-RT4	35.6	14.3	14.2	14.2	7.1	8000 (551)	4000 (275)
3/8	3/8	-PHN-NT6-RT6	36.3	17.5	14.2	14.2	9.7	7800 (537)	3900 (268)
1/2	1/2	-PHN-NT8-RT8	46.7	22.2	19.1	19.1	11.9	7700 (530)	3800 (261)
3/4	3/4	-PHN-NT12-RT12	46.7	27.0	19.1	19.1	15.7	7300 (502)	3600 (248)
1	1	-PHN-NT16-RT16	58.9	34.9	23.9	23.9	22.4	5300 (365)	2600 (179)

Male ISO Tapered Threads

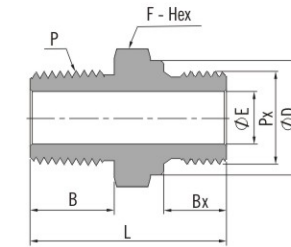

Male NPT Threads

P-NPT Size	Px-RS Size	Basic Ordering Number	Dimension, mm						Working Pressure psig (bar)	
			L	F	B	Bx	E	D	316 SS, Steel	Brass
1/8	1/8	-PHN-NT2-RS2	27.7	14.3	9.7	7.1	4.1	13.7	11400 (785)	5700 (392)
1/4	1/4	-PHN-NT4-RS4	36.8	19.1	14.2	11.2	5.8	18.0	10300 (709)	5100 (351)
3/8	3/8	-PHN-NT6-RS6	37.6	22.2	14.2	11.2	7.9	21.6	10300 (709)	5100 (351)
1/2	1/2	-PHN-NT8-RS8	44.4	27.0	19.1	14.2	11.9	25.9	7600 (523)	3800 (261)
3/4	3/4	-PHN-NT12-RS12	49.0	33.3	19.1	15.7	15.7	32.0	7300 (502)	3600 (248)
1	1	-PHN-NT16-RS16	56.6	41.3	23.9	18.3	19.8	38.9	7400 (509)	3700 (254)

Male ISO parallel Threads

Male NPT Threads

P-NPT Size	Px-SAE/MS Thread Size	Basic Ordering Number	Dimension, mm					Working Pressure psig (bar) 316 SS, Steel
			L	F	B	Bx	E	
1/4	7/16-20	-PHN-NT4-ST7	30.5	14.3	14.2	9.1	5.1	4500 (310)
3/8	9/16-18	-PHN-NT6-ST9	32.0	17.5	14.2	9.1	7.1	4500 (310)
1/2	3/4-16	-PHN-NT8-ST12	38.9	22.2	19.1	11.2	10.7	4500 (310)
3/4	1 1/16-12	-PHN-NT12-ST17	44.4	31.8	19.1	15.0	15.7	3600 (248)
1	1 5/16-12	-PHN-NT16-ST21	50.8	38.1	23.9	15.0	22.4	2900 (199)

Male SAE/MS Straight Threads

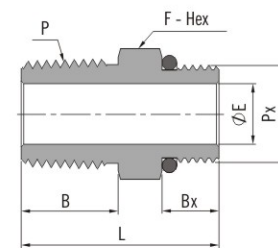

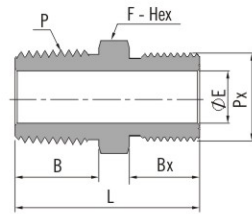

Male NPT Threads

P-NPT Size	Px-Metric Size	Basic Ordering Number	Dimension, mm					Working Pressure psig (bar) 316 SS, Steel
			L	F	B	Bx	E	
1/8	M20 x 1.5	-PHN-NT2-MM20	32.7	22.2	9.7	16	5.0	7700 (530)
1/4	M8 x 1	-PHN-NT4-MM8	29.0	14.3	14.2	9	3.2	8000 (551)
1/4	M14 x 1.5	-PHN-NT4-MM14	34.2	15.9	14.2	13	7.0	8000 (551)
1/4	M16 x 1.5	-PHN-NT4-MM16	35.2	17.5	14.2	14	7.1	7800 (537)
1/4	M20 x 1.5	-PHN-NT4-MM20	37.2	22.2	14.2	16	7.1	7700 (530)
3/8	M14 x 1.5	-PHN-NT6-MM14	34.2	17.5	14.2	13	7.0	7800 (537)
3/8	M20 x 1.5	-PHN-NT6-MM20	37.2	22.2	14.2	16	9.5	7700 (530)
3/8	M24 x 1.5	-PHN-NT6-MM24	38.2	25.4	14.2	17	9.5	7400 (509)
1/2	M14 x 1.5	-PHN-NT8-MM14	39.1	22.2	19.1	13	7.2	7700 (530)
1/2	M20 x 1.5	-PHN-NT8-MM20	42.0	22.2	19.1	16	10.0	7700 (530)
1/2	M24 x 1.5	-PHN-NT8-MM24	43.5	25.4	19.1	17	11.9	7400 (509)
3/4	M20 x 1.5	-PHN-NT12-MM20	42.1	27.0	19.1	16	10.8	7300 (502)
3/4	M27 x 2	-PHN-NT12-MM27	46.7	31.8	19.1	18	15.8	6100 (420)
1	M30 x 2	-PHN-NT16-MM30	56.3	34.9	23.9	20	19.4	6100 (420)

Male Metric Threads

Male ISO Tapered Threads

P-RT Size	Px-Metric Size	Basic Ordering Number	Dimension, mm					Working Pressure psig (bar) 316 SS, Steel
			L	F	B	Bx	E	
1/8	M20 x 1.5	-PHN-RT2-MM20	32.7	22.2	9.7	16	5.0	7700 (530)
1/4	M12 x 1.5	-PHN-RT4-MM12	33.4	14.3	14.2	12	6.0	8000 (551)
1/4	M20 x 1.5	-PHN-RT4-MM20	37.2	22.2	14.2	16	7.0	7700 (530)
3/8	M20 x 1.5	-PHN-RT6-MM20	37.2	22.2	14.2	16	9.5	7700 (530)
1/2	M20 x 1.5	-PHN-RT8-MM20	42.0	22.2	19.1	16	10.0	7700 (530)

Male Metric Threads

Male ISO Parallel Threads

P-RS Size	Px-Metric Size	Basic Ordering Number	Dimension, mm						Working Pressure psig (bar) 316 SS, Steel
			L	F	B	Bx	E	D	
1/8	M20 x 1.5	-PHN-RS2-MM20	32.6	22.2	7.1	16	4.0	13.7	7700 (530)
1/4	M18 x 1.5	-PHN-RS4-MM18	34.2	20.6	11.2	15	5.9	18.0	7800 (537)
1/4	M20 x 1.5	-PHN-RS4-MM20	37.2	22.2	11.2	16	5.9	18.0	7700 (530)
3/8	M20 x 1.5	-PHN-RS6-MM20	37.2	22.2	11.2	16	7.9	21.6	7700 (530)
1/2	M20 x 1.5	-PHN-RS8-MM20	40.2	27.0	14.0	16	11.9	25.9	7700 (530)

Male Metric Threads

Male Metric Threads

P-Metric Size	Px-Metric Size	Basic Ordering Number	Dimension, mm					Working Pressure psig (bar) 316 SS, Steel
			L	F	B	Bx	E	
M20 x 1.5	M10 x 1	-PHN-MM20-MM10	34.0	22	16	11	4.0	10000 (689)
M20 x 1.5	M12 x 1.5	-PHN-MM20-MM12	35.0	22	16	12	6.0	9000 (620)
M20 x 1.5	M14 x 1.5	-PHN-MM20-MM14	36.0	22	16	13	7.2	8000 (551)
M20 x 1.5	M16 x 1.5	-PHN-MM20-MM16	37.0	22	16	14	9.0	7800 (537)
M20 x 1.5	M20 x 1.5	-PHN-MM20	39.0	22	16	16	10.8	7700 (530)
M27 x 2	M27 x 2	-PHN-MM27	44.5	30	18	18	16.1	7300 (502)

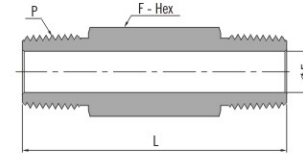
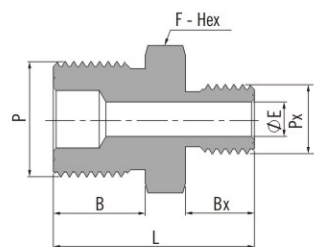
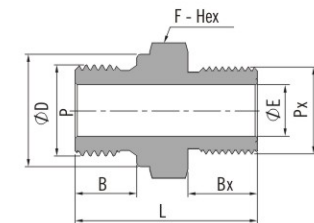

Male NPT Threads

P-NPT Size	Basic Ordering Number	Dimension, mm			Working Pressure psig (bar)	
		L	F	E	316 SS, Steel	Brass
1/8	-PLN-NT2-38.1	38.1	11.1	4.8	10000 (689)	5000 (344)
1/8	-PLN-NT2-50.8	50.8	11.1	4.8	10000 (689)	5000 (344)
1/8	-PLN-NT2-63.5	63.5	11.1	4.8	10000 (689)	5000 (344)
1/8	-PLN-NT2-76.2	76.2	11.1	4.8	10000 (689)	5000 (344)
1/4	-PLN-NT4-38.1	38.1	14.3	7.1	8000 (551)	4000 (275)
1/4	-PLN-NT4-50.8	50.8	14.3	7.1	8000 (551)	4000 (275)
1/4	-PLN-NT4-63.5	63.5	14.3	7.1	8000 (551)	4000 (275)
1/4	-PLN-NT4-76.2	76.2	14.3	7.1	8000 (551)	4000 (275)
1/4	-PLN-NT4-101.6	101.6	14.3	7.1	8000 (551)	4000 (275)
3/8	-PLN-NT6-38.1	38.1	17.5	9.7	7800 (537)	3900 (268)
3/8	-PLN-NT6-50.8	50.8	17.5	9.7	7800 (537)	3900 (268)
3/8	-PLN-NT6-63.5	63.5	17.5	9.7	7800 (537)	3900 (268)
3/8	-PLN-NT6-76.2	76.2	17.5	9.7	7800 (537)	3900 (268)
3/8	-PLN-NT6-101.6	101.6	17.5	9.7	7800 (537)	3900 (268)
1/2	-PLN-NT8-50.8	50.8	22.2	11.9	7700 (530)	3800 (261)
1/2	-PLN-NT8-76.2	76.2	22.2	11.9	7700 (530)	3800 (261)
1/2	-PLN-NT8-101.6	101.6	22.2	11.9	7700 (530)	3800 (261)
1/2	-PLN-NT8-152.4	152.4	22.2	11.9	7700 (530)	3800 (261)
3/4	-PLN-NT12-50.8	50.8	27.0	15.7	7300 (502)	3600 (248)
3/4	-PLN-NT12-76.2	76.2	27.0	15.7	7300 (502)	3600 (248)
3/4	-PLN-NT12-101.6	101.6	27.0	15.7	7300 (502)	3600 (248)
1	-PLN-NT16-76.2	76.2	34.9	22.4	5300 (365)	2600 (179)
1	-PLN-NT16-101.6	101.6	34.9	22.4	5300 (365)	2600 (179)

Male ISO Tapered Threads

P-RT Size	Basic Ordering Number	Dimension, mm			Working Pressure psig (bar)	
		L	F	E	316 SS, Steel	Brass
1/8	-PLN-RT2-38.1	38.1	11.1	4.8	10000 (689)	5000 (344)
1/8	-PLN-RT2-50.8	50.8	11.1	4.8	10000 (689)	5000 (344)
1/8	-PLN-RT2-63.5	63.5	11.1	4.8	10000 (689)	5000 (344)
1/8	-PLN-RT2-76.2	76.2	11.1	4.8	10000 (689)	5000 (344)
1/4	-PLN-RT4-38.1	38.1	14.3	7.1	8000 (551)	4000 (275)
1/4	-PLN-RT4-50.8	50.8	14.3	7.1	8000 (551)	4000 (275)
1/4	-PLN-RT4-63.5	63.5	14.3	7.1	8000 (551)	4000 (275)
1/4	-PLN-RT4-76.2	76.2	14.3	7.1	8000 (551)	4000 (275)
1/4	-PLN-RT4-101.6	101.6	14.3	7.1	8000 (551)	4000 (275)
3/8	-PLN-RT6-38.1	38.1	17.5	9.7	7800 (537)	3900 (268)
3/8	-PLN-RT6-50.8	50.8	17.5	9.7	7800 (537)	3900 (268)
3/8	-PLN-RT6-63.5	63.5	17.5	9.7	7800 (537)	3900 (268)
3/8	-PLN-RT6-76.2	76.2	17.5	9.7	7800 (537)	3900 (268)
3/8	-PLN-RT6-101.6	101.6	17.5	9.7	7800 (537)	3900 (268)
1/2	-PLN-RT8-50.8	50.8	22.2	11.9	7700 (530)	3800 (261)
1/2	-PLN-RT8-76.2	76.2	22.2	11.9	7700 (530)	3800 (261)
1/2	-PLN-RT8-101.6	101.6	22.2	11.9	7700 (530)	3800 (261)
1/2	-PLN-RT8-152.4	152.4	22.2	11.9	7700 (530)	3800 (261)
3/4	-PLN-RT12-50.8	50.8	27.0	15.7	7300 (502)	3600 (248)
3/4	-PLN-RT12-76.2	76.2	27.0	15.7	7300 (502)	3600 (248)
3/4	-PLN-RT12-101.6	101.6	27.0	15.7	7300 (502)	3600 (248)
1	-PLN-RT16-76.2	76.2	34.9	22.4	5300 (365)	2600 (179)
1	-PLN-RT16-101.6	101.6	34.9	22.4	5300 (365)	2600 (179)

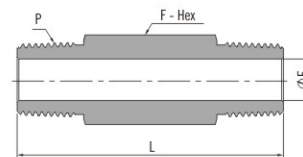

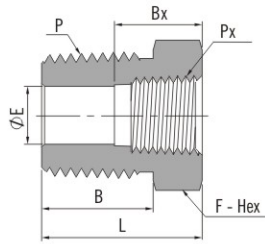

Male NPT Threads

P-NPT Size	Px-NPT Size	Basic Ordering Number	Dimension, mm					Working Pressure psig (bar)	
			L	F	B	Bx	E	316 SS, Steel	Brass
			1/8	1/16	-PRB-NT2-NT1	26.2	11.1	9.7	9.9
1/4	1/16	-PRB-NT4-NT1	21.8	14.3	14.2	9.9	4.8	8000 (551)	4000 (275)
1/4	1/8	-PRB-NT4-NT2	26.9	14.3	14.2	10.4	7.1	6500 (447)	3300 (227)
3/8	1/16	-PRB-NT6-NT1	21.8	17.5	14.2	9.9	4.8	13300 (971)	6600 (454)
3/8	1/8	-PRB-NT6-NT2	21.8	17.5	14.2	10.4	8.6	9200 (633)	4700 (323)
3/8	1/4	-PRB-NT6-NT4	30.2	19.1	14.2	15.0	9.6	6600 (454)	3300 (227)
1/2	1/8	-PRB-NT8-NT2	27.4	22.2	19.1	10.4	8.6	12200 (840)	6200 (427)
1/2	1/4	-PRB-NT8-NT4	27.4	22.2	19.1	15.0	11.4	8300 (571)	4400 (303)
1/2	3/8	-PRB-NT8-NT6	35.8	22.2	19.1	15.0	11.9	5300 (365)	2600 (179)
3/4	1/8	-PRB-NT12-NT2	27.4	27.0	19.1	10.4	7.1	20000(1378)	10000(689)
3/4	1/4	-PRB-NT12-NT4	27.4	27.0	19.1	15.0	11.4	12000 (826)	6000 (410)
3/4	3/8	-PRB-NT12-NT6	27.4	27.0	19.1	15.0	15.0	8200 (564)	4300 (296)
3/4	1/2	-PRB-NT12-NT8	41.4	27.0	19.1	19.8	15.7	4900 (337)	2400 (165)
1	1/8	-PRB-NT16-NT2	34.5	34.9	23.9	10.4	7.1	20000(1378)	10000(689)
1	1/4	-PRB-NT16-NT4	34.8	34.9	23.9	15.0	11.4	14500 (999)	7400 (509)
1	3/8	-PRB-NT16-NT6	34.8	34.9	23.9	15.0	15.0	11600 (799)	5900 (406)
1	1/2	-PRB-NT16-NT8	34.8	34.9	23.9	19.8	18.5	8600 (592)	4300 (296)
1	3/4	-PRB-NT16-NT12	47.0	34.9	23.9	20.6	22.4	5300 (365)	2600 (179)
1 1/4	3/4	-PRB-NT20-NT12	37.3	44.5	23.9	20.6	22.4	7800 (537)	3900 (268)
1 1/4	1	-PRB-NT20-NT16	37.3	44.5	23.9	25.4	22.4	3500 (241)	1750 (120)
1 1/2	1	-PRB-NT24-NT16	40.1	50.8	26.2	25.4	22.4	6600 (454)	3300 (227)
1 1/2	1 1/4	-PRB-NT24-NT20	56.0	54.0	26.2	25.4	34.0	5000 (344)	2500 (172)

Male NPT Threads

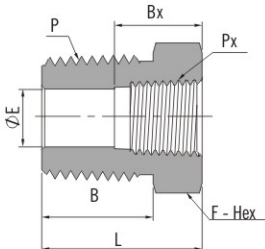

Female ISO Tapered Threads

P-NPT Size	Px-RT Size	Basic Ordering Number	Dimension, mm					Working Pressure psig (bar)	
			L	F	B	Bx	E	316 SS, Steel	Brass
			1/8	1/16	-PRB-NT2-RT1	26.2	11.1	9.7	9.9
1/4	1/16	-PRB-NT4-RT1	21.8	14.3	14.2	9.9	4.8	8000 (551)	4000 (275)
1/4	1/8	-PRB-NT4-RT2	26.9	14.3	14.2	10.4	7.1	6500 (447)	3300 (227)
3/8	1/16	-PRB-NT6-RT1	21.8	17.5	14.2	9.9	4.8	13300 (917)	6600 (454)
3/8	1/8	-PRB-NT6-RT2	21.8	17.5	14.2	10.4	7.1	9200 (633)	4700 (323)
3/8	1/4	-PRB-NT6-RT4	30.2	19.1	14.2	15.0	9.7	6600 (454)	3300 (227)
1/2	1/8	-PRB-NT8-RT2	27.4	22.2	19.1	10.4	7.1	12200 (840)	6200 (427)
1/2	1/4	-PRB-NT8-RT4	27.4	22.2	19.1	15.0	10.4	8300 (571)	4400 (303)
1/2	3/8	-PRB-NT8-RT6	35.8	22.2	19.1	15.0	11.9	5300 (365)	2600 (179)
3/4	1/8	-PRB-NT12-RT2	27.4	27.0	19.1	10.4	7.1	20000 (1378)	10000 (689)
3/4	1/4	-PRB-NT12-RT4	27.4	27.0	19.1	15.0	10.4	12000 (826)	6000 (410)
3/4	3/8	-PRB-NT12-RT6	27.4	27.0	19.1	15.0	12.7	8200 (564)	4300 (296)
3/4	1/2	-PRB-NT12-RT8	41.4	27.0	19.1	19.8	15.7	4900 (337)	2400 (165)
1	1/8	-PRB-NT16-RT2	34.5	34.9	23.9	10.4	7.1	20000 (1378)	10000 (689)
1	1/4	-PRB-NT16-RT4	34.8	34.9	23.9	15.0	10.4	14500 (999)	7400 (509)
1	3/8	-PRB-NT16-RT6	34.8	34.9	23.9	15.0	12.7	11600 (799)	5900 (406)
1	1/2	-PRB-NT16-RT8	34.8	34.9	23.9	19.8	15.7	8600 (592)	4300 (296)
1	3/4	-PRB-NT16-RT12	47.0	34.9	23.9	20.6	22.4	5300 (365)	2600 (179)
1 1/4	3/4	-PRB-NT20-RT12	37.3	44.5	23.9	20.6	22.4	7800 (537)	3900 (268)
1 1/4	1	-PRB-NT20-RT16	37.3	44.5	23.9	25.4	22.4	3500 (241)	1750 (120)
1 1/2	1	-PRB-NT24-RT16	40.1	50.8	26.2	25.4	22.4	6600 (454)	3300 (227)
1 1/2	1 1/4	-PRB-NT24-RT20	56.0	54.0	26.2	25.4	34.0	5000 (344)	2500 (172)

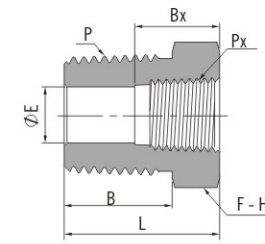

Male ISO Tapered Threads

P-RT Size	Px-RT Size	Basic Ordering Number	Dimension, mm					Working Pressure psig (bar)	
			L	F	B	Bx	E	316 SS, Steel	Brass
			1/4	1/8	-PRB-RT4-RT2	26.9	14.3	14.2	10.4
3/8	1/4	-PRB-RT6-RT4	30.2	19.1	14.2	15.0	9.6	6600 (454)	3300 (227)
1/2	1/4	-PRB-RT8-RT4	27.4	22.2	19.1	15.0	11.2	8300 (571)	4400 (303)
1/2	3/8	-PRB-RT8-RT6	35.8	22.2	19.1	15.0	11.9	5300 (365)	2600 (179)

Female ISO Tapered Threads

Male NPT Threads

P-NPT Size	Px-RG Size	Basic Ordering Number	Dimension, mm					Working Pressure psig (bar) 316 SS, Steel
			L	F	B	Bx	E	
			3/8	1/4	-PRB-NT6-RG4	30.2	19.1	
1/2	3/8	-PRB-NT8-RG6	35.8	22.2	19.1	14.2	6.6	5700 (392)
3/4	1/2	-PRB-NT12-RG8	41.4	27.0	19.1	18.8	7.1	3900 (268)

Female ISO Parallel Threads

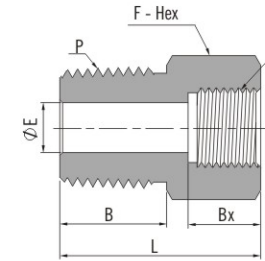

Male ISO Parallel Threads

P-MG Size	Px-NPT Size	Basic Ordering Number	Dimension, mm					Working Pressure psig (bar)	
			L	F	B	Bx	E	316 SS, Steel	Brass
			1/4	1/8	-PRB-MG4-NT2	26.9	14.3	12.9	10.4
3/8	1/4	-PRB-MG6-NT4	31.0	19.1	14.2	15	7.1	6600 (454)	3300 (227)
1/2	3/8	-PRB-MG8-NT6	35.8	22.2	18.8	15	6.6	5300 (365)	2600 (179)

Female NPT Threads

Male SAE/MS Straight Threads

P-SAE/MS Thread Size	Px-SAE/MS Thread Size	Basic Ordering Number	Dimension, mm					Working Pressure psig (bar) 316 SS, Steel
			L	F	B	Bx	E	
			9/16-18	7/16-20	-PRB-ST9-US7	28.4	20.6	
3/4-16	7/16-20	-PRB-ST12-US7	24.9	22.2	11.2	14.0	9.9	4500 (310)
3/4-16	9/16-18	-PRB-ST12-US9	30.2	25.4	11.2	16.0	10.7	4500 (310)
7/8-14	9/16-18	-PRB-ST14-US9	27.9	25.4	12.7	16.0	12.7	3600 (248)
7/8-14	3/4-16	-PRB-ST14-US12	36.1	30.2	12.7	18.0	12.7	3600 (248)
1 1/16-12	3/4-16	-PRB-ST17-US12	32.3	31.8	15.0	18.0	16.5	3600 (248)
1 5/16-12	1 1/16-12	-PRB-ST21-US17	40.9	41.3	15.0	24.0	22.1	2900 (199)
1 5/8-12	1 5/16-12	-PRB-ST26-US21	50.3	54.0	15.0	24.0	27.7	2300 (158)
1 7/8-12	1 5/16-12	-PRB-ST30-US21	50.3	54.0	15.0	24.0	31.2	2300 (158)

Female SAE/MS Straight Threads

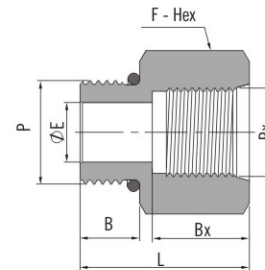

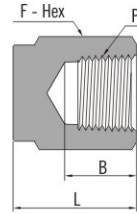

Female NPT Threads

P-NPT Size	Basic Ordering Number	Dimension, mm			Working Pressure psig (bar)	
		L	F	B	316 SS, Steel	Brass
1/16	-PC-NT1	12.7	11.1	9.9	6700 (460)	3300 (227)
1/8	-PC-NT2	19.1	14.3	10.4	6500 (447)	3200 (220)
1/4	-PC-NT4	23.1	19.1	15.0	6600 (454)	3300 (277)
3/8	-PC-NT6	26.2	22.2	15.0	5300 (365)	2600 (179)
1/2	-PC-NT8	34.0	27.0	19.8	4900 (337)	2400 (165)
3/4	-PC-NT12	36.6	33.3	20.6	4600 (316)	2300 (158)
1	-PC-NT16	41.1	41.3	25.4	4400 (303)	2200 (151)
Heavy-Wall Female NPT Threads						
1/4	-PC-NT4-10K	28.2	25.4	15.0	10000 (689)	/
1/2	-PC-NT8-10K	40.1	38.1	19.8	10000 (689)	/

Female ISO Tapered Threads

P-RT Size	Basic Ordering Number	Dimension, mm			Working Pressure psig (bar)	
		L	F	B	316 SS, Steel	Brass
1/16	-PC-RT1	12.7	11.1	9.9	6700 (460)	3300 (227)
1/8	-PC-RT2	19.1	14.3	10.4	6500 (447)	3200 (220)
1/4	-PC-RT4	23.1	19.1	15.0	6600 (454)	3300 (277)
3/8	-PC-RT6	26.2	22.2	15.0	5300 (365)	2600 (179)
1/2	-PC-RT8	34.0	27.0	19.8	4900 (337)	2400 (165)
3/4	-PC-RT12	36.6	33.3	20.6	4600 (316)	2300 (158)
1	-PC-RT16	41.1	41.3	25.4	4400 (303)	2200 (151)

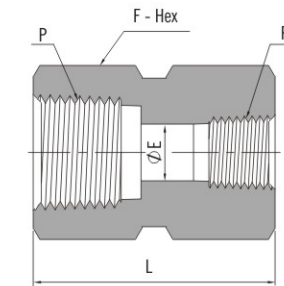

Female NPT Threads

P-NPT Size	Px-NPT Size	Basic Ordering Number	Dimension, mm			Working Pressure psig (bar)	
			L	F	E	316 SS, Steel	Brass
1/16	1/16	-PCG-NT1	19.8	11.1	4.8	6700 (460)	3300 (227)
1/8	1/8	-PCG-NT2	20.6	14.3	8.6	6500 (447)	3200 (220)
1/4	1/8	-PCG-NT4-NT2	31.0	19.1	8.6	6600 (454)	3300 (227)
1/4	1/4	-PCG-NT4	30.2	19.1	11.4	6600 (454)	3300 (227)
3/8	1/4	-PCG-NT6-NT4	35.1	22.2	11.4	5300 (365)	2600 (179)
3/8	3/8	-PCG-NT6	33.3	22.2	15.0	5300 (365)	2600 (179)
1/2	1/8	-PCG-NT8-NT2	39.6	27.0	8.6	4900 (337)	2400 (165)
1/2	1/4	-PCG-NT8-NT4	44.4	27.0	11.4	4900 (337)	2400 (165)
1/2	3/8	-PCG-NT8-NT6	45.2	27.0	15.0	4900 (337)	2400 (165)
1/2	1/2	-PCG-NT8	39.6	27.0	18.5	4900 (337)	2400 (165)
3/4	1/4	-PCG-NT12-NT4	46.0	33.3	11.4	4600 (316)	2300 (158)
3/4	1/2	-PCG-NT12-NT8	52.3	33.3	18.5	4600 (316)	2300 (158)
3/4	3/4	-PCG-NT12	41.1	33.3	23.9	4600 (316)	2300 (158)
1	1/2	-PCG-NT16-NT8	55.6	41.3	18.5	4400 (303)	2200 (151)
1	3/4	-PCG-NT16-NT12	57.2	41.3	23.9	4400 (303)	2200 (151)
1	1	-PCG-NT16	50.8	41.3	29.7	4400 (303)	2200 (151)
Heavy-Wall Female NPT Threads							
1/4	1/4	-PCG-NT4-10K	30.2	25.4	11.4	10000 (689)	/
1/2	1/2	-PCG-NT8-10K	39.6	38.1	18.5	10000 (689)	/
1/2	1/4	-PCG-NT8-NT4-10K	44.4	38.1	11.4	10000 (689)	/

Female ISO Tapered Threads

P-RT Size	Px-RT Size	Basic Ordering Number	Dimension, mm			Working Pressure psig (bar)	
			L	F	E	316 SS, Steel	Brass
1/8	1/8	-PCG-RT2	20.6	14.3	8.4	6500 (447)	3200 (220)
1/4	1/4	-PCG-RT4	30.2	19.1	11.2	6600 (454)	3300 (227)
3/8	1/4	-PCG-RT6-RT4	35.1	22.2	11.2	5300 (365)	2600 (179)
3/8	3/8	-PCG-RT6	33.3	22.2	14.7	5300 (365)	2600 (179)
1/2	1/4	-PCG-RT8-RT4	44.4	27.0	11.2	4900 (337)	2400 (165)
1/2	3/8	-PCG-RT8-RT6	45.2	27.0	14.7	4900 (337)	2400 (165)
1/2	1/2	-PCG-RT8	39.6	27.0	18.3	4900 (337)	2400 (165)

Union Ball Joints

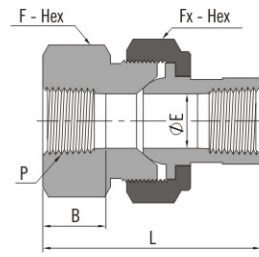

Female NPT Threads

P-NPT Size	Basic Ordering Number	Dimension, mm					Working Pressure psig (bar) 316 SS, Steel
		L	F	Fx	B	E	
1/8	-UBJ-NT2	46.0	23.8	28.6	10.4	6.8	8400 (578)
1/4	-UBJ-NT4	59.4	30.2	34.9	15.0	9.1	6600 (454)
3/8	-UBJ-NT6	63.5	33.3	38.1	15.0	13.2	5300 (365)
1/2	-UBJ-NT8	68.3	41.3	44.5	19.8	15.7	6000 (410)
3/4	-UBJ-NT12	79.2	47.6	54.0	20.6	22.4	4600 (316)
1	-UBJ-NT16	90.4	60.3	63.5	25.4	26.2	6800 (468)

Female ISO Tapered Threads

P-RT Size	Basic Ordering Number	Dimension, mm					Working Pressure psig (bar) 316 SS, Steel
		L	F	Fx	B	E	
1/8	-UBJ-RT2	46.0	23.8	28.6	10.4	6.8	8400 (578)
1/4	-UBJ-RT4	59.4	30.2	34.9	15.0	9.1	6600 (454)
3/8	-UBJ-RT6	63.5	33.3	38.1	15.0	13.2	5300 (365)
1/2	-UBJ-RT8	68.3	41.3	44.5	19.8	15.7	6000 (410)
3/4	-UBJ-RT12	79.2	47.6	54.0	20.6	22.4	4600 (316)
1	-UBJ-RT16	90.4	60.3	63.5	25.4	26.2	6800 (468)

Adapters

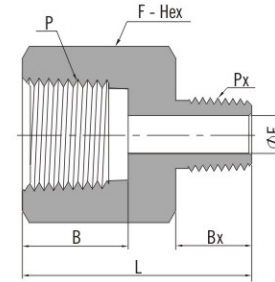

Female NPT Threads

P-NPT Size	Px-NPT Size	Basic Ordering Number	Dimension, mm					Working Pressure psig (bar)	
			L	F	B	Bx	E	316 SS, Steel	Brass
1/8	1/16	-PA-NT2-NT1	27.7	14.3	10.4	9.7	3.0	6500 (447)	3200 (220)
1/8	1/8	-PA-NT2	27.9	14.3	10.4	9.7	4.8	6500 (447)	3200 (220)
1/4	1/16	-PA-NT4-NT1	30.5	19.1	15.0	9.7	3.0	6600 (454)	3300 (227)
1/4	1/8	-PA-NT4-NT2	32.0	19.1	15.0	9.7	4.8	6600 (454)	3300 (227)
1/4	1/4	-PA-NT4	35.6	19.1	15.0	14.2	7.1	6600 (454)	3300 (227)
3/8	1/16	-PA-NT6-NT1	31.8	22.2	15.0	9.7	3.0	5300 (365)	2600 (179)
3/8	1/8	-PA-NT6-NT2	33.8	22.2	15.0	9.7	4.8	5300 (365)	2600 (179)
3/8	1/4	-PA-NT6-NT4	38.1	22.2	15.0	14.2	7.1	5300 (365)	2600 (179)
3/8	3/8	-PA-NT6	38.4	22.2	15.0	14.2	9.6	5300 (365)	2600 (179)
1/2	1/8	-PA-NT8-NT2	40.1	27.0	19.8	9.7	4.8	4900 (337)	2400 (165)
1/2	1/4	-PA-NT8-NT4	44.7	27.0	19.8	14.2	7.1	4900 (337)	2400 (165)
1/2	3/8	-PA-NT8-NT6	44.4	27.0	19.8	14.2	9.6	4900 (337)	2400 (165)
1/2	1/2	-PA-NT8	49.3	27.0	19.8	19.1	11.9	4900 (337)	2400 (165)
3/4	1/8	-PA-NT12-NT2	39.6	33.3	20.6	9.7	4.8	4600 (316)	2300 (158)
3/4	1/4	-PA-NT12-NT4	47.0	33.3	20.6	14.2	7.1	4600 (316)	2300 (158)
3/4	3/8	-PA-NT12-NT6	46.2	33.3	20.6	14.2	9.6	4600 (316)	2300 (158)
3/4	1/2	-PA-NT12-NT8	51.3	33.3	20.6	19.1	11.9	4600 (316)	2300 (158)
3/4	3/4	-PA-NT12	51.3	33.3	20.6	19.1	15.7	4600 (316)	2300 (158)
1	1/8	-PA-NT16-NT2	46.0	41.3	25.4	9.7	4.8	4400 (303)	2200 (151)
1	1/4	-PA-NT16-NT4	49.8	41.3	25.4	14.2	7.1	4400 (303)	2200 (151)
1	3/8	-PA-NT16-NT6	50.8	41.3	25.4	14.2	9.6	4400 (303)	2200 (151)
1	1/2	-PA-NT16-NT8	54.9	41.3	25.4	19.1	11.9	4400 (303)	2200 (151)
1	3/4	-PA-NT16-NT12	55.1	41.3	25.4	19.1	15.7	4400 (303)	2200 (151)
1	1	-PA-NT16	57.9	41.3	25.4	23.9	22.4	4400 (303)	2200 (151)
1 1/4	1	-PA-NT20-NT16	62.7	54.0	25.4	23.9	22.4	5000 (344)	2500 (172)
Heavy-Wall Female to male NPT Threads									
1/4	1/4	-PA-NT4-10K	36.3	25.4	15.0	14.2	5.8	10000 (689)	/
1/2	1/2	-PA-NT8-10K	51.3	38.1	19.8	19.1	9.9	10000 (689)	/
1/2	1/4	-PA-NT8-NT4-10K	46.0	38.1	19.8	14.2	5.8	10000 (689)	/

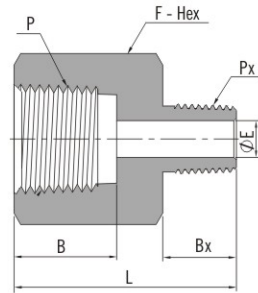

Female NPT Threads			Male ISO Tapered Threads							
P-NPT Size	Px-RT Size	Basic Ordering Number	Dimension, mm					Working Pressure psig (bar)		
			L	F	B	Bx	E	316 SS, Steel	Brass	
1/8	1/8	-PA-NT2-RT2	27.7	14.3	10.4	9.7	4.8	6500 (447)	3200 (220)	
1/4	1/4	-PA-NT4-RT4	36.1	19.1	15.0	14.2	7.1	6600 (454)	3300 (227)	
3/8	3/8	-PA-NT6-RT6	38.1	22.2	15.0	14.2	9.6	5300 (365)	2600 (179)	
1/2	1/2	-PA-NT8-RT8	49.3	27.0	19.8	19.1	11.9	4900 (337)	2400 (165)	
3/4	3/4	-PA-NT12-RT12	51.3	33.3	20.6	19.1	15.7	4600 (316)	2300 (158)	
1	1	-PA-NT16-RT16	58.4	41.3	25.4	23.9	22.4	4400 (303)	2200 (151)	

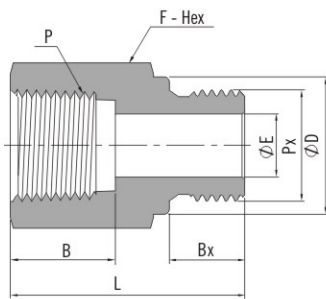

Female NPT Threads			Male ISO Parallel Threads							
P-NPT Size	Px-RS Size	Basic Ordering Number	Dimension, mm					Working Pressure psig (bar)		
			L	F	B	Bx	D	E	316 SS, Steel	Brass
1/8	1/8	-PA-NT2-RS2	25.1	14.3	9.9	7.1	13.7	4.1	6500 (447)	3200 (220)
1/4	1/4	-PA-NT4-RS4	33.5	19.1	10.4	11.2	18.0	5.8	6600 (454)	3300 (227)
3/8	3/8	-PA-NT6-RS6	35.8	22.2	15.0	11.2	21.6	7.9	5300 (365)	2600 (179)
1/2	1/2	-PA-NT8-RS8	44.2	27.0	15.0	14.2	25.9	11.9	4900 (337)	2400 (165)
3/4	3/4	-PA-NT12-RS12	48.0	33.3	20.6	15.7	32.0	15.7	4600 (316)	2300 (158)
1	1	-PA-NT16-RS16	53.3	41.3	25.4	18.3	38.9	19.8	4400 (303)	2200 (151)

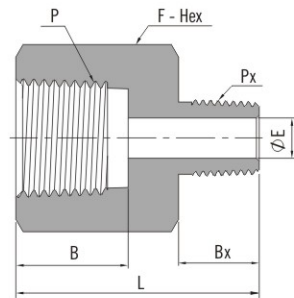

Female ISO Tapered Threads			Male ISO Tapered Threads							
P-RT Size	Px-RT Size	Basic Ordering Number	Dimension, mm					Working Pressure psig (bar)		
			L	F	B	Bx	E	316 SS, Steel	Brass	
1/8	1/8	-PA-RT2	27.7	14.3	10.4	9.7	4.8	6500 (447)	3200 (220)	
1/4	1/8	-PA-RT4-RT2	32.0	19.1	15.0	9.7	4.8	6600 (454)	3300 (227)	
1/4	1/4	-PA-RT4	36.1	19.1	15.0	14.2	7.1	6600 (454)	3300 (227)	
3/8	1/4	-PA-RT6-RT4	38.1	22.2	15.0	14.2	7.1	5300 (365)	2600 (179)	
3/8	3/8	-PA-RT6	38.1	22.2	15.0	14.2	9.7	5300 (365)	2600 (179)	
1/2	1/4	-PA-RT8-RT4	44.7	27.0	19.8	14.2	7.1	4900 (337)	2400 (165)	
1/2	3/8	-PA-RT8-RT6	44.4	27.0	19.8	14.2	9.7	4900 (337)	2400 (165)	
1/2	1/2	-PA-RT8	49.5	27.0	19.8	19.1	11.9	4900 (337)	2400 (165)	
3/4	3/4	-PA-RT12	51.3	33.3	20.6	19.1	15.7	4600 (316)	2300 (158)	
1	1	-PA-RT16	58.4	41.3	25.4	23.9	22.4	4400 (303)	2200 (151)	

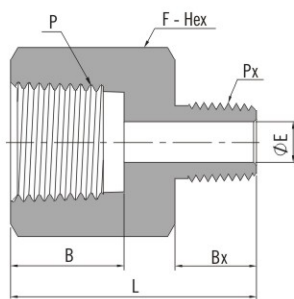

Female ISO Tapered Threads			Male NPT Threads							
P-RT Size	Px-NPT Size	Basic Ordering Number	Dimension, mm					Working Pressure psig (bar)		
			L	F	B	Bx	E	316 SS, Steel	Brass	
1/8	1/8	-PA-RT2-NT2	27.7	14.3	10.4	9.7	4.8	6500 (447)	3200 (220)	
1/4	1/4	-PA-RT4-NT4	36.3	19.1	15.0	14.2	7.1	6600 (454)	3300 (227)	
3/8	3/8	-PA-RT6-NT6	38.4	22.2	15.0	14.2	9.6	5300 (365)	2600 (179)	
1/2	1/2	-PA-RT8-NT8	49.8	27.0	19.8	19.1	11.9	4900 (337)	2400 (165)	
3/4	3/4	-PA-RT12-NT12	51.3	33.3	20.6	19.1	15.7	4600 (316)	2300 (158)	
1	1	-PA-RT16-NT16	58.4	41.3	25.4	23.9	22.4	4400 (303)	2200 (151)	

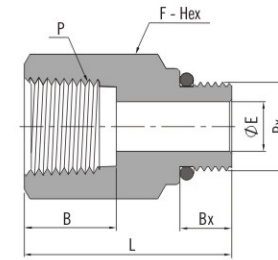

Female NPT Threads			Male SAE/MS Straight Threads					
P-NPT Size	Px-SAE/MS Thread Size	Basic Ordering Number	Dimension, mm					Working Pressure psig (bar) 316 SS, Steel
			L	F	B	Bx	E	
1/4	7/16-20	-PA-NT4-ST7	33.5	19.1	15.0	9.1	5.1	4500 (310)
3/8	9/16-18	-PA-NT6-ST9	35.3	23.8	15.0	9.9	7.1	4500 (310)
1/2	3/4-16	-PA-NT8-ST12	44.7	27.0	19.8	11.2	10.7	4500 (310)
3/4	1 1/16-12	-PA-NT12-ST17	50.5	34.9	20.6	15.0	16.8	3600 (248)
1	1 5/16-12	-PA-NT16-ST21	53.8	41.3	25.4	15.0	21.5	2900 (199)

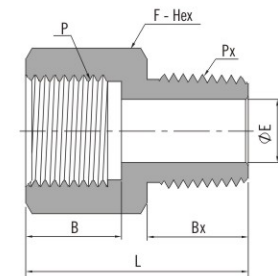

Female ISO Parallel Threads			Male NPT Threads					
P-RG Size	Px-NPT Size	Basic Ordering Number	Dimension, mm					Working Pressure psig (bar) 316 SS, Steel
			L	F	B	Bx	E	
1/8	1/8	-PA-RG2-NT2	21.8	14.3	6.5	9.7	4.5	6100 (420)
1/4	1/4	-PA-RG4-NT4	30.2	19.1	12.9	14.2	5.5	5700 (392)
3/8	3/8	-PA-RG6-NT6	32.2	23.8	14.2	14.2	6.5	5700 (392)
1/2	1/2	-PA-RG8-NT8	42.7	27.0	18.8	19.1	7.0	3900 (268)

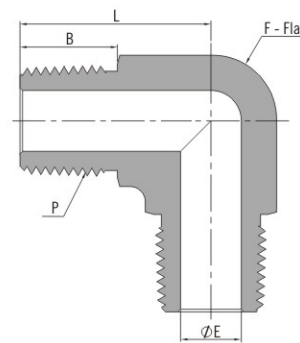

Male NPT Threads			Dimension, mm				Working Pressure psig (bar)	
P-NPT Size	Basic Ordering Number	L	F	B	E	316 SS, Steel		
						Brass		
1/16	-PME-NT1	18.3	9.5	9.7	3.0	11000 (757)	5500 (378)	
1/8	-PME-NT2	22.4	11.1	9.7	4.8	10000 (689)	5000 (344)	
1/4	-PME-NT4	26.7	12.7	14.2	7.1	8000 (551)	4000 (275)	
3/8	-PME-NT6	29.7	17.5	14.2	9.6	7800 (537)	3900 (268)	
1/2	-PME-NT8	36.8	20.6	19.1	11.9	7700 (530)	3800 (261)	
3/4	-PME-NT12	40.4	27.0	19.1	15.7	7300 (502)	3600 (248)	
1	-PME-NT16	50.0	34.9	23.9	22.4	5300 (365)	2600 (179)	

Male ISO Tapered Threads			Dimension, mm				Working Pressure psig (bar)	
P-RT Size	Basic Ordering Number	L	F	B	E	316 SS, Steel		
						Brass		
1/16	-PME-RT1	18.3	9.5	9.7	3.0	11000 (757)	5500 (378)	
1/8	-PME-RT2	22.4	11.1	9.7	4.8	10000 (689)	5000 (344)	
1/4	-PME-RT4	26.7	12.7	14.2	7.1	8000 (551)	4000 (275)	
3/8	-PME-RT6	29.7	17.5	14.2	9.6	7800 (537)	3900 (268)	
1/2	-PME-RT8	36.8	20.6	19.1	11.9	7700 (530)	3800 (261)	
3/4	-PME-RT12	40.4	27.0	19.1	15.7	7300 (502)	3600 (248)	
1	-PME-RT16	50.0	34.9	23.9	22.4	5300 (365)	2600 (179)	

Street Elbows

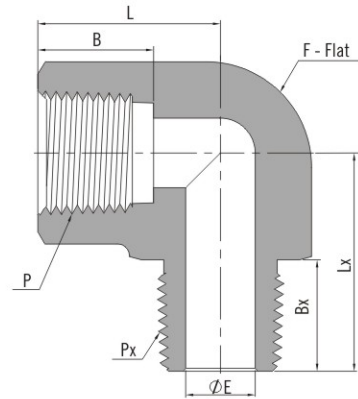

Female NPT Threads

Male NPT Threads

P-NPT Size	Px-NPT Size	Basic Ordering Number	Dimension, mm						Working Pressure psig (bar)	
			L	F	B	E	Lx	Bx	316 SS, Steel	Brass
			1/16	1/16	-PSE-NT1	21.8	11.1	9.9	3.0	22.4
1/16	1/8	-PSE-NT1-NT2	21.8	11.1	9.9	4.8	22.4	9.7	9200 (633)	4600 (316)
1/16	1/4	-PSE-NT1-NT4	22.4	14.3	9.9	4.8	27.7	14.2	8000 (551)	4000 (275)
1/16	3/8	-PSE-NT1-NT6	22.4	17.5	9.9	4.8	29.7	14.2	7800 (537)	3900 (268)
1/8	1/16	-PSE-NT2-NT1	26.4	12.7	10.4	3.0	22.1	9.7	6200 (426)	3100 (213)
1/8	1/8	-PSE-NT2	26.4	12.7	10.4	4.8	22.1	9.7	6200 (426)	3100 (213)
1/8	1/4	-PSE-NT2-NT4	22.4	14.3	10.4	7.1	27.7	14.2	6500 (447)	3200 (220)
1/8	3/8	-PSE-NT2-NT6	22.4	17.5	10.4	7.1	29.7	14.2	7800 (537)	3900 (268)
1/8	1/2	-PSE-NT2-NT8	24.1	20.6	10.4	7.1	36.8	19.1	7700 (530)	3800 (261)
1/8	3/4	-PSE-NT2-NT12	25.4	27.0	10.4	7.1	40.4	19.1	7300 (502)	3600 (248)
1/8	1	-PSE-NT2-NT16	26.4	34.9	10.4	7.1	50.0	23.9	5300 (365)	2600 (179)
1/4	1/8	-PSE-NT4-NT2	29.7	17.5	15.0	4.8	25.4	9.7	7200 (496)	3600 (248)
1/4	1/4	-PSE-NT4	29.7	17.5	15.0	7.1	29.7	14.2	7200 (496)	3600 (248)
1/4	3/8	-PSE-NT4-NT6	29.7	17.5	15.0	8.6	29.7	14.2	7200 (496)	3600 (248)
1/4	1/2	-PSE-NT4-NT8	25.4	20.6	15.0	8.6	36.8	19.1	7200 (496)	3600 (248)
1/4	3/4	-PSE-NT4-NT12	25.4	27.0	15.0	8.6	40.4	19.1	7300 (502)	3600 (248)
1/4	1	-PSE-NT4-NT16	41.4	34.9	15.0	8.6	50.0	23.9	5300 (365)	2600 (179)
3/8	1/4	-PSE-NT6-NT4	36.1	20.6	15.0	7.1	32.0	14.2	5600 (385)	2800 (192)
3/8	3/8	-PSE-NT6	36.1	20.6	15.0	9.6	32.0	14.2	5600 (385)	2800 (192)
3/8	1/2	-PSE-NT6-NT8	36.1	20.6	15.0	11.9	36.8	19.1	5600 (385)	2800 (192)
3/8	3/4	-PSE-NT6-NT12	31.2	27.0	15.0	11.9	40.4	19.1	7300 (502)	3600 (248)
3/8	1	-PSE-NT6-NT16	41.4	34.9	15.0	11.9	50.0	23.9	5300 (365)	2600 (179)
1/2	1/4	-PSE-NT8-NT4	39.6	25.4	19.8	7.1	35.1	14.2	5600 (385)	2800 (192)
1/2	3/8	-PSE-NT8-NT6	39.6	25.4	19.8	9.6	35.1	14.2	5600 (385)	2800 (192)
1/2	1/2	-PSE-NT8	39.6	25.4	19.8	11.9	39.6	19.1	5600 (385)	2800 (192)
1/2	3/4	-PSE-NT8-NT12	31.2	27.0	19.8	15.7	40.4	19.1	5600 (385)	2800 (192)
1/2	1	-PSE-NT8-NT16	41.4	34.9	19.8	15.7	50.0	23.9	5300 (365)	2600 (179)
3/4	3/4	-PSE-NT12	48.8	31.8	20.6	15.7	42.4	19.1	5100 (351)	2500 (172)
3/4	1	-PSE-NT12-NT16	41.4	34.9	20.6	22.4	50.0	23.9	5100 (351)	2500 (172)
1	1	-PSE-NT16	48.5	42.9	25.4	22.4	49.3	23.9	5300 (365)	2600 (179)
1 1/4	1 1/4	-PSE-NT20	60.5	50.8	25.4	31.8	60.5	23.9	3100 (213)	1600 (110)

Street Elbows

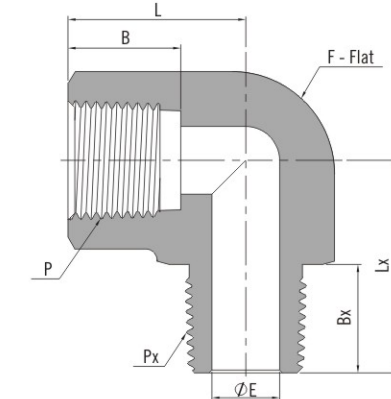

Female ISO Tapered Threads

Male ISO Tapered Threads

P-RT Size	Px-RT Size	Basic Ordering Number	Dimension, mm						Working Pressure psig (bar)	
			L	F	B	E	Lx	Bx	316 SS, Steel	Brass
			1/16	1/16	-PSE-RT1	21.8	11.1	9.9	3.0	22.4
1/16	1/8	-PSE-RT1-RT2	21.8	11.1	9.9	4.8	22.4	9.7	9200 (633)	4600 (316)
1/16	1/4	-PSE-RT1-RT4	22.4	14.3	9.9	4.8	27.7	14.2	8000 (551)	4000 (275)
1/16	3/8	-PSE-RT1-RT6	22.4	17.5	9.9	4.8	29.7	14.2	7800 (537)	3900 (268)
1/8	1/16	-PSE-RT2-RT1	26.4	12.7	10.4	3.0	22.1	9.7	6200 (426)	3100 (213)
1/8	1/8	-PSE-RT2	26.4	12.7	10.4	4.8	22.1	9.7	6200 (426)	3100 (213)
1/8	1/4	-PSE-RT2-RT4	22.4	14.3	10.4	7.1	27.7	14.2	6500 (447)	3200 (220)
1/8	3/8	-PSE-RT2-RT6	22.4	17.5	10.4	7.1	29.7	14.2	7800 (537)	3900 (268)
1/8	1/2	-PSE-RT2-RT8	24.1	20.6	10.4	7.1	36.8	19.1	7700 (530)	3800 (261)
1/8	3/4	-PSE-RT2-RT12	25.4	27.0	10.4	7.1	40.4	19.1	7300 (502)	3600 (248)
1/8	1	-PSE-RT2-RT16	26.4	34.9	10.4	7.1	50.0	23.9	5300 (365)	2600 (179)
1/4	1/8	-PSE-RT4-RT2	29.7	17.5	15.0	4.8	25.4	9.7	7200 (496)	3600 (248)
1/4	1/4	-PSE-RT4	29.7	17.5	15.0	7.1	29.7	14.2	7200 (496)	3600 (248)
1/4	3/8	-PSE-RT4-RT6	29.7	17.5	15.0	8.6	29.7	14.2	7200 (496)	3600 (248)
1/4	1/2	-PSE-RT4-RT8	25.4	20.6	15.0	8.6	36.8	19.1	7200 (496)	3600 (248)
1/4	3/4	-PSE-RT4-RT12	25.4	27.0	15.0	8.6	40.4	19.1	7300 (502)	3600 (248)
1/4	1	-PSE-RT4-RT16	41.4	34.9	15.0	8.6	50.0	23.9	5300 (365)	2600 (179)
3/8	1/4	-PSE-RT6-RT4	36.1	20.6	15.0	7.1	32.0	14.2	5600 (385)	2800 (192)
3/8	3/8	-PSE-RT6	36.1	20.6	15.0	9.6	32.0	14.2	5600 (385)	2800 (192)
3/8	1/2	-PSE-RT6-RT8	36.1	20.6	15.0	11.9	36.8	19.1	5600 (385)	2800 (192)
3/8	3/4	-PSE-RT6-RT12	31.2	27.0	15.0	11.9	40.4	19.1	7300 (502)	3600 (248)
3/8	1	-PSE-RT6-RT16	41.4	34.9	15.0	11.9	50.0	23.9	5300 (365)	2600 (179)
1/2	1/4	-PSE-RT8-RT4	39.6	25.4	19.8	7.1	35.1	14.2	5600 (385)	2800 (192)
1/2	3/8	-PSE-RT8-RT6	39.6	25.4	19.8	9.6	35.1	14.2	5600 (385)	2800 (192)
1/2	1/2	-PSE-RT8	39.6	25.4	19.8	11.9	39.6	19.1	5600 (385)	2800 (192)
1/2	3/4	-PSE-RT8-RT12	31.2	27.0	19.8	15.7	40.4	19.1	5600 (385)	2800 (192)
1/2	1	-PSE-RT8-RT16	41.4	34.9	19.8	15.7	50.0	23.9	5300 (365)	2600 (179)
3/4	3/4	-PSE-RT12	48.8	31.8	20.6	15.7	42.4	19.1	5100 (351)	2500 (172)
3/4	1	-PSE-RT12-RT16	41.4	34.9	20.6	22.4	50.0	23.9	5100 (351)	2500 (172)
1	1	-PSE-RT16	48.5	42.9	25.4	22.4	49.3	23.9	5300 (365)	2600 (179)
1 1/4	1 1/4	-PSE-RT20	60.5	50.8	25.4	31.8	60.5	23.9	3100 (213)	1600 (110)

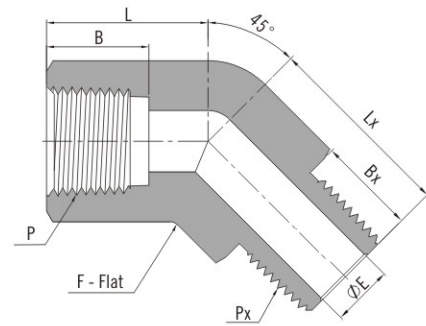

Female NPT Threads

Male NPT Threads

P-NPT Size	Px-NPT Size	Basic Ordering Number	Dimension, mm						Working Pressure psig (bar)	
			L	F	B	E	Lx	Bx	316 SS, Steel	Brass
1/16	1/16	-PSV-NT1	16.8	11.1	9.9	3.0	16.8	9.7	9200 (633)	4600 (316)
1/16	1/8	-PSV-NT1-NT2	16.8	11.1	9.9	4.8	16.8	9.7	9200 (633)	4600 (316)
1/16	1/4	-PSV-NT1-NT4	16.8	14.3	9.9	4.8	21.8	14.2	8000 (551)	4000 (275)
1/16	3/8	-PSV-NT1-NT6	22.4	17.5	9.9	4.8	23.8	14.2	7800 (537)	3900 (268)
1/8	1/16	-PSV-NT2-NT1	20.2	12.7	10.4	3.0	17.2	9.7	6200 (426)	3100 (213)
1/8	1/8	-PSV-NT2	20.2	12.7	10.4	4.8	17.2	9.7	6200 (426)	3100 (213)
1/8	1/4	-PSV-NT2-NT4	16.8	14.3	10.4	7.1	21.8	14.2	6500 (447)	3200 (220)
1/8	3/8	-PSV-NT2-NT6	22.4	17.5	10.4	7.1	23.8	14.2	7800 (537)	3900 (268)
1/8	1/2	-PSV-NT2-NT8	22.2	20.6	10.4	7.1	29.0	19.1	7700 (530)	3800 (261)
1/8	3/4	-PSV-NT2-NT12	25.4	27.0	10.4	7.1	30.5	19.1	7300 (502)	3600 (248)
1/8	1	-PSV-NT2-NT16	26.4	34.9	10.4	7.1	49.3	23.9	5300 (365)	2600 (179)
1/4	1/8	-PSV-NT4-NT2	25.4	17.5	15.0	4.8	19.3	9.7	7200 (496)	3600 (248)
1/4	1/4	-PSV-NT4	25.4	17.5	15.0	7.1	19.3	14.2	7200 (496)	3600 (248)
1/4	3/8	-PSV-NT4-NT6	25.4	17.5	15.0	8.6	23.8	14.2	7200 (496)	3600 (248)
1/4	1/2	-PSV-NT4-NT8	22.2	20.6	15.0	8.6	29.0	19.1	7200 (496)	3600 (248)
1/4	3/4	-PSV-NT4-NT12	25.4	27.0	15.0	8.6	30.5	19.1	7300 (502)	3600 (248)
1/4	1	-PSV-NT4-NT16	32.0	34.9	15.0	8.6	37.6	23.9	5300 (365)	2600 (179)
3/8	1/4	-PSV-NT6-NT4	27.0	20.6	15.0	7.1	24.2	14.2	5600 (385)	2800 (192)
3/8	3/8	-PSV-NT6	27.0	20.6	15.0	9.6	24.2	14.2	5600 (385)	2800 (192)
3/8	1/2	-PSV-NT6-NT8	27.0	20.6	15.0	11.9	29.0	19.1	5600 (385)	2800 (192)
3/8	3/4	-PSV-NT6-NT12	27.0	27.0	15.0	11.9	30.5	19.1	7300 (502)	3600 (248)
3/8	1	-PSV-NT6-NT16	32.0	34.9	15.0	11.9	37.6	23.9	5300 (365)	2600 (179)
1/2	1/4	-PSV-NT8-NT4	32.0	25.4	19.8	7.1	25.2	14.2	5600 (385)	2800 (192)
1/2	3/8	-PSV-NT8-NT6	32.0	25.4	19.8	9.6	25.2	14.2	5600 (385)	2800 (192)
1/2	1/2	-PSV-NT8	32.0	25.4	19.8	11.9	32.0	19.1	5600 (385)	2800 (192)
1/2	3/4	-PSV-NT8-NT12	32.5	27.0	19.8	15.7	30.5	19.1	5600 (385)	2800 (192)
1/2	1	-PSV-NT8-NT16	37.6	34.9	19.8	15.7	37.6	23.9	5300 (365)	2600 (179)
3/4	3/4	-PSV-NT12	34.5	31.8	20.6	15.7	34.5	19.1	5100 (351)	2500 (172)
3/4	1	-PSV-NT12-NT16	37.6	34.9	20.6	22.4	37.6	23.9	5100 (351)	2500 (172)
1	1	-PSV-NT16	46.0	42.9	25.4	22.4	46.0	23.9	5300 (365)	2600 (179)
1 1/4	1 1/4	-PSV-NT20	50.8	50.8	25.4	31.8	50.8	23.9	3100 (213)	1600 (110)

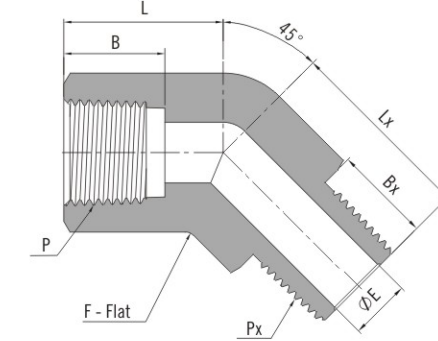

Female ISO Tapered Threads

Male ISO Tapered Threads

P-RT Size	Px-RT Size	Basic Ordering Number	Dimension, mm						Working Pressure psig (bar)	
			L	F	B	E	Lx	Bx	316 SS, Steel	Brass
1/16	1/16	-PSV-RT1	16.8	11.1	9.9	3.0	16.8	9.7	9200 (633)	4600 (316)
1/16	1/8	-PSV-RT1-RT2	16.8	11.1	9.9	4.8	16.8	9.7	9200 (633)	4600 (316)
1/16	1/4	-PSV-RT1-RT4	16.8	14.3	9.9	4.8	21.8	14.2	8000 (551)	4000 (275)
1/16	3/8	-PSV-RT1-RT6	22.4	17.5	9.9	4.8	23.8	14.2	7800 (537)	3900 (268)
1/8	1/16	-PSV-RT2-RT1	20.2	12.7	10.4	3.0	17.2	9.7	6200 (426)	3100 (213)
1/8	1/8	-PSV-RT2	20.2	12.7	10.4	4.8	17.2	9.7	6200 (426)	3100 (213)
1/8	1/4	-PSV-RT2-RT4	16.8	14.3	10.4	7.1	21.8	14.2	6500 (447)	3200 (220)
1/8	3/8	-PSV-RT2-RT6	22.4	17.5	10.4	7.1	23.8	14.2	7800 (537)	3900 (268)
1/8	1/2	-PSV-RT2-RT8	22.2	20.6	10.4	7.1	29.0	19.1	7700 (530)	3800 (261)
1/8	3/4	-PSV-RT2-RT12	25.4	27.0	10.4	7.1	30.5	19.1	7300 (502)	3600 (248)
1/8	1	-PSV-RT2-RT16	26.4	34.9	10.4	7.1	49.3	23.9	5300 (365)	2600 (179)
1/4	1/8	-PSV-RT4-RT2	25.4	17.5	15.0	4.8	19.3	9.7	7200 (496)	3600 (248)
1/4	1/4	-PSV-RT4	25.4	17.5	15.0	7.1	19.3	14.2	7200 (496)	3600 (248)
1/4	3/8	-PSV-RT4-RT6	25.4	17.5	15.0	8.6	23.8	14.2	7200 (496)	3600 (248)
1/4	1/2	-PSV-RT4-RT8	22.2	20.6	15.0	8.6	29.0	19.1	7200 (496)	3600 (248)
1/4	3/4	-PSV-RT4-RT12	25.4	27.0	15.0	8.6	30.5	19.1	7300 (502)	3600 (248)
1/4	1	-PSV-RT4-RT16	32.0	34.9	15.0	8.6	37.6	23.9	5300 (365)	2600 (179)
3/8	1/4	-PSV-RT6-RT4	27.0	20.6	15.0	7.1	24.2	14.2	5600 (385)	2800 (192)
3/8	3/8	-PSV-RT6	27.0	20.6	15.0	9.6	24.2	14.2	5600 (385)	2800 (192)
3/8	1/2	-PSV-RT6-RT8	27.0	20.6	15.0	11.9	29.0	19.1	5600 (385)	2800 (192)
3/8	3/4	-PSV-RT6-RT12	27.0	27.0	15.0	11.9	30.5	19.1	7300 (502)	3600 (248)
3/8	1	-PSV-RT6-RT16	32.0	34.9	15.0	11.9	37.6	23.9	5300 (365)	2600 (179)
1/2	1/4	-PSV-RT8-RT4	32.0	25.4	19.8	7.1	25.2	14.2	5600 (385)	2800 (192)
1/2	3/8	-PSV-RT8-RT6	32.0	25.4	19.8	9.6	25.2	14.2	5600 (385)	2800 (192)
1/2	1/2	-PSV-RT8	32.0	25.4	19.8	11.9	32.0	19.1	5600 (385)	2800 (192)
1/2	3/4	-PSV-RT8-RT12	32.5	27.0	19.8	15.7	30.5	19.1	5600 (385)	2800 (192)
1/2	1	-PSV-RT8-RT16	37.6	34.9	19.8	15.7	37.6	23.9	5300 (365)	2600 (179)
3/4	3/4	-PSV-RT12	34.5	31.8	20.6	15.7	34.5	19.1	5100 (351)	2500 (172)
3/4	1	-PSV-RT12-RT16	37.6	34.9	20.6	22.4	37.6	23.9	5100 (351)	2500 (172)
1	1	-PSV-RT16	46.0	42.9	25.4	22.4	46.0	23.9	5300 (365)	2600 (179)
1 1/4	1 1/4	-PSV-RT20	50.8	50.8	25.4	31.8	50.8	23.9	3100 (213)	1600 (110)

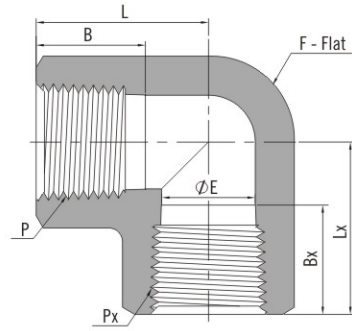

Female NPT Threads

P-NPT Size	Px-NPT Size	Basic Ordering Number	Dimension, mm						Working Pressure psig (bar)	
			L	F	B	E	Lx	Bx	316 SS, Steel	Brass
1/16	1/16	-PE-NT1	21.8	11.1	9.9	4.8	21.8	9.9	6700 (460)	3300 (227)
1/8	1/16	-PE-NT2-NT1	26.4	12.7	10.4	4.8	26.4	9.9	6200 (427)	3100 (213)
1/8	1/8	-PE-NT2	26.4	12.7	10.4	7.1	26.4	10.4	6200 (427)	3100 (213)
1/4	1/8	-PE-NT4-NT2	29.7	17.5	15.0	7.1	29.7	10.4	7200 (496)	3600 (248)
1/4	1/4	-PE-NT4	29.7	17.5	15.0	10.4	29.7	15.0	7200 (496)	3600 (248)
3/8	3/8	-PE-NT6	36.1	20.6	15.0	12.7	36.1	15.0	5600 (385)	2800 (192)
1/2	1/2	-PE-NT8	39.6	25.4	19.8	17.1	39.6	19.8	5600 (385)	2800 (192)
3/4	3/4	-PE-NT12	48.8	31.8	20.6	22.4	48.8	20.6	5100 (351)	2500 (172)
1	1	-PE-NT16	48.5	42.9	25.4	28.1	48.5	25.4	6400 (440)	3200 (220)
1 1/4	1 1/4	-PE-NT20	59.8	50.8	25.4	27.7	59.8	25.4	3100 (213)	1600 (110)
1 1/2	1 1/2	-PE-NT24	65.0	63.5	27.7	34.0	65.0	27.7	5100 (351)	2500 (172)
Heavy-Wall Female NPT Threads										
1/4	1/4	-PE-NT4-10K	39.6	25.4	15.0	11.4	29.7	15.0	10000 (689)	/
1/2	1/2	-PE-NT8-10K	50.0	42.9	19.8	18.5	39.6	19.8	10000 (689)	/

Female ISO Tapered Threads

P-RT Size	Px-RT Size	Basic Ordering Number	Dimension, mm						Working Pressure psig (bar)	
			L	F	B	E	Lx	Bx	316 SS, Steel	Brass
1/16	1/16	-PE-RT1	21.8	11.1	9.9	4.8	21.8	9.9	6700 (460)	3300 (227)
1/8	1/16	-PE-RT2-RT1	26.4	12.7	10.4	4.8	26.4	9.9	6200 (427)	3100 (213)
1/8	1/8	-PE-RT2	26.4	12.7	10.4	7.1	26.4	10.4	6200 (427)	3100 (213)
1/4	1/8	-PE-RT4-RT2	29.7	17.5	15.0	7.1	29.7	10.4	7200 (496)	3600 (248)
1/4	1/4	-PE-RT4	29.7	17.5	15.0	10.4	29.7	15.0	7200 (496)	3600 (248)
3/8	3/8	-PE-RT6	36.1	20.6	15.0	12.7	36.1	15.0	5600 (385)	2800 (192)
1/2	1/2	-PE-RT8	39.6	25.4	19.8	17.1	39.6	19.8	5600 (385)	2800 (192)
3/4	3/4	-PE-RT12	48.8	31.8	20.6	22.4	48.8	20.6	5100 (351)	2500 (172)
1	1	-PE-RT16	48.5	42.9	25.4	28.1	48.5	25.4	6400 (440)	3200 (220)
1 1/4	1 1/4	-PE-RT20	59.8	50.8	25.4	27.7	59.8	25.4	3100 (213)	1600 (110)
1 1/2	1 1/2	-PE-RT24	65.0	63.5	27.7	34.0	65.0	27.7	5100 (351)	2500 (172)

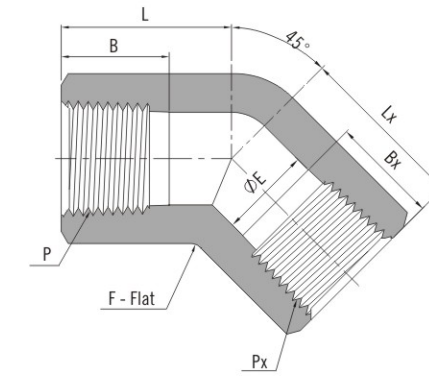

Female NPT Threads

P-NPT Size	Px-NPT Size	Basic Ordering Number	Dimension, mm						Working Pressure psig (bar)	
			L	F	B	E	Lx	Bx	316 SS, Steel	Brass
1/16	1/16	-PVE-NT1	16.8	11.1	9.9	4.8	16.8	9.9	6700 (460)	3300 (227)
1/8	1/16	-PVE-NT2-NT1	20.2	12.7	10.4	4.8	20.2	9.9	6200 (427)	3100 (213)
1/8	1/8	-PVE-NT2	20.2	12.7	10.4	7.1	20.2	10.4	6200 (427)	3100 (213)
1/4	1/8	-PVE-NT4-NT2	25.4	17.5	15.0	7.1	25.4	10.4	7200 (496)	3600 (248)
1/4	1/4	-PVE-NT4	25.4	17.5	15.0	10.4	25.4	15.0	7200 (496)	3600 (248)
3/8	3/8	-PVE-NT6	27.0	20.6	15.0	12.7	27.0	15.0	5600 (385)	2800 (192)
1/2	1/2	-PVE-NT8	32.0	25.4	19.8	17.1	32.0	19.8	5600 (385)	2800 (192)
3/4	3/4	-PVE-NT12	34.5	31.8	20.6	22.4	34.5	20.6	5100 (351)	2500 (172)
1	1	-PVE-NT16	46.0	42.9	25.4	28.1	46.0	25.4	6400 (440)	3200 (220)
1 1/4	1 1/4	-PVE-NT20	43.2	50.8	25.4	27.7	43.2	25.4	3100 (213)	1600 (110)
1 1/2	1 1/2	-PVE-NT24	46.0	63.5	27.7	34.0	46.0	27.7	5100 (351)	2500 (172)

Female ISO Tapered Threads

P-RT Size	Px-RT Size	Basic Ordering Number	Dimension, mm						Working Pressure psig (bar)	
			L	F	B	E	Lx	Bx	316 SS, Steel	Brass
1/16	1/16	-PVE-RT1	16.8	11.1	9.9	4.8	16.8	9.9	6700 (460)	3300 (227)
1/8	1/16	-PVE-RT2-RT1	20.2	12.7	10.4	4.8	20.2	9.9	6200 (427)	3100 (213)
1/8	1/8	-PVE-RT2	20.2	12.7	10.4	7.1	20.2	10.4	6200 (427)	3100 (213)
1/4	1/8	-PVE-RT4-RT2	25.4	17.5	15.0	7.1	25.4	10.4	7200 (496)	3600 (248)
1/4	1/4	-PVE-RT4	25.4	17.5	15.0	10.4	25.4	15.0	7200 (496)	3600 (248)
3/8	3/8	-PVE-RT6	27.0	20.6	15.0	12.7	27.0	15.0	5600 (385)	2800 (192)
1/2	1/2	-PVE-RT8	32.0	25.4	19.8	17.1	32.0	19.8	5600 (385)	2800 (192)
3/4	3/4	-PVE-RT12	34.5	31.8	20.6	22.4	34.5	20.6	5100 (351)	2500 (172)
1	1	-PVE-RT16	46.0	42.9	25.4	28.1	46.0	25.4	6400 (440)	3200 (220)
1 1/4	1 1/4	-PVE-RT20	43.2	50.8	25.4	27.7	43.2	25.4	3100 (213)	1600 (110)
1 1/2	1 1/2	-PVE-RT24	46.0	63.5	27.7	34.0	46.0	27.7	5100 (351)	2500 (172)

Male Tees

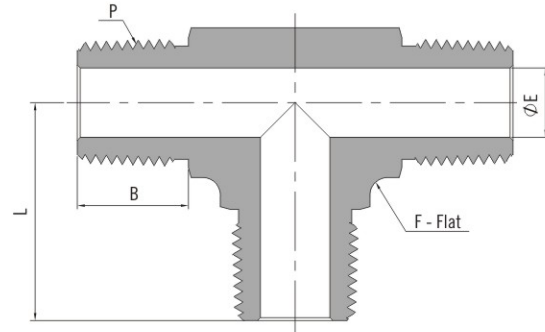

Male NPT Threads

P-NPT Size	Basic Ordering Number	Dimension, mm				Working Pressure psig (bar)	
		L	F	B	E	316 SS, Steel	Brass
1/16	-PMT-NT1	18.3	9.5	9.7	3.0	11000 (757)	5500 (378)
1/8	-PMT-NT2	22.4	11.1	9.7	4.8	10000 (689)	5000 (344)
1/4	-PMT-NT4	26.7	12.7	14.2	7.1	8000 (551)	4000 (275)
3/8	-PMT-NT6	29.7	17.5	14.2	9.6	7800 (537)	3900 (268)
1/2	-PMT-NT8	36.8	20.6	19.1	11.9	7700 (530)	3800 (261)
3/4	-PMT-NT12	42.4	27.0	19.1	15.7	7300 (502)	3600 (248)
1	-PMT-NT16	49.3	34.9	23.9	22.4	5300 (365)	2600 (179)
1 1/4	-PMT-NT20	56.4	42.9	23.9	27.7	6000 (410)	3000 (200)
1 1/2	-PMT-NT24	67.1	47.6	26.2	34.0	5000 (344)	2500 (172)

Male ISO Tapered Threads

P-RT Size	Basic Ordering Number	Dimension, mm				Working Pressure psig (bar)	
		L	F	B	E	316 SS, Steel	Brass
1/16	-PMT-RT1	18.3	9.5	9.7	3.0	11000 (757)	5500 (378)
1/8	-PMT-RT2	22.4	11.1	9.7	4.8	10000 (689)	5000 (344)
1/4	-PMT-RT4	26.7	12.7	14.2	7.1	8000 (551)	4000 (275)
3/8	-PMT-RT6	29.7	17.5	14.2	9.6	7800 (537)	3900 (268)
1/2	-PMT-RT8	36.8	20.6	19.1	11.9	7700 (530)	3800 (261)
3/4	-PMT-RT12	42.4	27.0	19.1	15.7	7300 (502)	3600 (248)
1	-PMT-RT16	49.3	34.9	23.9	22.4	5300 (365)	2600 (179)
1 1/4	-PMT-RT20	56.4	42.9	23.9	27.7	6000 (410)	3000 (200)
1 1/2	-PMT-RT24	67.1	47.6	26.2	34.0	5000 (344)	2500 (172)

Female Branch Tees

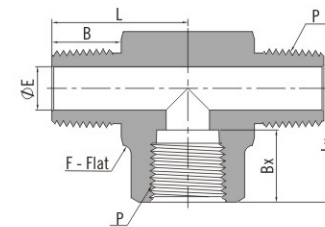

NPT Threads

P-NPT Size	Basic Ordering Number	Dimension, mm						Working Pressure psig (bar)	
		L	F	E	B	Lx	Bx	316 SS, Steel	Brass
1/16	-PTB-NT1	18.3	11.1	3.0	9.7	21.8	9.9	9200 (633)	4600 (316)
1/8	-PTB-NT2	22.1	12.7	4.8	9.7	26.4	10.4	6200 (427)	3100 (213)
1/4	-PTB-NT4	29.7	17.5	7.1	14.2	29.7	15.0	7200 (496)	3600 (248)
3/8	-PTB-NT6	32.0	20.6	9.6	14.2	36.1	15.0	5600 (385)	2800 (192)
1/2	-PTB-NT8	39.6	25.4	11.9	19.1	39.6	19.8	5600 (385)	2800 (192)
3/4	-PTB-NT12	42.4	31.8	15.7	19.1	48.8	20.6	5100 (351)	2500 (172)
1	-PTB-NT16	49.3	42.9	22.4	23.9	48.5	25.4	5300 (365)	2600 (179)

ISO Tapered Threads

P-RT Size	Basic Ordering Number	Dimension, mm						Working Pressure psig (bar)	
		L	F	E	B	Lx	Bx	316 SS, Steel	Brass
1/16	-PTB-RT1	18.3	11.1	3.0	9.7	21.8	9.9	9200 (633)	4600 (316)
1/8	-PTB-RT2	22.1	12.7	4.8	9.7	26.4	10.4	6200 (427)	3100 (213)
1/4	-PTB-RT4	29.7	17.5	7.1	14.2	29.7	15.0	7200 (496)	3600 (248)
3/8	-PTB-RT6	32.0	20.6	9.6	14.2	36.1	15.0	5600 (385)	2800 (192)
1/2	-PTB-RT8	39.6	25.4	11.9	19.1	39.6	19.8	5600 (385)	2800 (192)
3/4	-PTB-RT12	42.4	31.8	15.7	19.1	48.8	20.6	5100 (351)	2500 (172)
1	-PTB-RT16	49.3	42.9	22.4	23.9	48.5	25.4	5300 (365)	2600 (179)

Female Run Tees

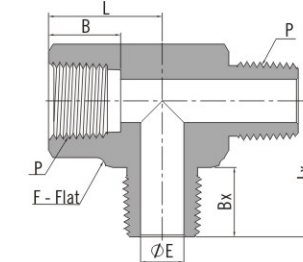

NPT Threads

P-NPT Size	Basic Ordering Number	Dimension, mm						Working Pressure psig (bar)	
		L	F	E	B	Lx	Bx	316 SS, Steel	Brass
1/16	-PTR-NT1	21.8	11.1	3.0	9.9	18.3	9.7	9200 (633)	4600 (316)
1/8	-PTR-NT2	26.4	12.7	4.8	10.4	22.1	9.7	6200 (427)	3100 (213)
1/4	-PTR-NT4	29.7	17.5	7.1	15.0	29.7	14.2	7200 (496)	3600 (248)
3/8	-PTR-NT6	36.1	20.6	9.6	15.0	32.0	14.2	5600 (385)	2800 (192)
1/2	-PTR-NT8	39.6	25.4	11.9	19.8	39.6	19.1	5600 (385)	2800 (192)
3/4	-PTR-NT12	48.8	31.8	15.7	20.6	42.4	19.1	5100 (351)	2500 (172)
1	-PTR-NT16	48.5	42.9	22.4	25.4	49.3	23.9	5300 (365)	2600 (179)

ISO Tapered Threads

P-RT Size	Basic Ordering Number	Dimension, mm						Working Pressure psig (bar)	
		L	F	E	B	Lx	Bx	316 SS, Steel	Brass
1/16	-PTB-RT1	21.8	11.1	3.0	9.9	18.3	9.7	9200 (633)	4600 (316)
1/8	-PTB-RT2	26.4	12.7	4.8	10.4	22.1	9.7	6200 (427)	3100 (213)
1/4	-PTB-RT4	29.7	17.5	7.1	15.0	29.7	14.2	7200 (496)	3600 (248)
3/8	-PTB-RT6	36.1	20.6	9.6	15.0	32.0	14.2	5600 (385)	2800 (192)
1/2	-PTB-RT8	39.6	25.4	11.9	19.8	39.6	19.1	5600 (385)	2800 (192)
3/4	-PTB-RT12	48.8	31.8	15.7	20.6	42.4	19.1	5100 (351)	2500 (172)
1	-PTB-RT16	48.5	42.9	22.4	25.4	49.3	23.9	5300 (365)	2600 (179)

Male Street Tees

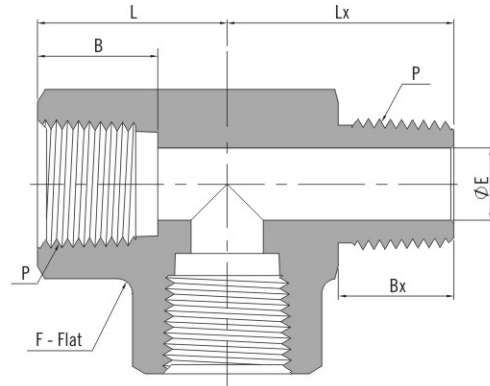

NPT Threads

P-NPT Size	Basic Ordering Number	Dimension, mm						Working Pressure psig (bar)	
		L	F	E	B	Lx	Bx	316 SS, Steel	Brass
1/16	-PST-NT1	21.8	11.1	3.0	9.9	18.3	9.7	9200 (633)	4600 (316)
1/8	-PST-NT2	26.4	12.7	4.8	10.4	22.1	9.7	6200 (427)	3100 (213)
1/4	-PST-NT4	29.7	17.5	7.1	15.0	29.7	14.2	7200 (496)	3600 (248)
3/8	-PST-NT6	36.1	20.6	9.6	15.0	32.0	14.2	5600 (385)	2800 (192)
1/2	-PST-NT8	39.6	25.4	11.9	19.8	39.6	19.1	5600 (385)	2800 (192)
3/4	-PST-NT12	48.8	31.8	15.7	20.6	42.4	19.1	5100 (351)	2500 (172)
1	-PST-NT16	48.5	42.9	22.4	25.4	49.3	23.9	5300 (365)	2600 (179)

ISO Tapered Threads

P-RT Size	Basic Ordering Number	Dimension, mm						Working Pressure psig (bar)	
		L	F	E	B	Lx	Bx	316 SS, Steel	Brass
1/16	-PBT-RT1	21.8	11.1	3.0	9.9	18.3	9.7	9200 (633)	4600 (316)
1/8	-PBT-RT2	26.4	12.7	4.8	10.4	22.1	9.7	6200 (427)	3100 (213)
1/4	-PBT-RT4	29.7	17.5	7.1	15.0	29.7	14.2	7200 (496)	3600 (248)
3/8	-PBT-RT6	36.1	20.6	9.6	15.0	32.0	14.2	5600 (385)	2800 (192)
1/2	-PBT-RT8	39.6	25.4	11.9	19.8	39.6	19.1	5600 (385)	2800 (192)
3/4	-PBT-RT12	48.8	31.8	15.7	20.6	42.4	19.1	5100 (351)	2500 (172)
1	-PBT-RT16	48.5	42.9	22.4	25.4	49.3	23.9	5300 (365)	2600 (179)

Male Branch Tees

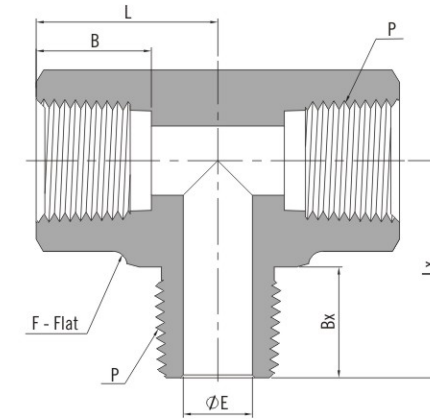

NPT Threads

P-NPT Size	Basic Ordering Number	Dimension, mm						Working Pressure psig (bar)	
		L	F	E	B	Lx	Bx	316 SS, Steel	Brass
1/16	-PBT-NT1	21.8	11.1	3.0	9.9	18.3	9.7	9200 (633)	4600 (316)
1/8	-PBT-NT2	26.4	12.7	4.8	10.4	22.1	9.7	6200 (427)	3100 (213)
1/4	-PBT-NT4	29.7	17.5	7.1	15.0	29.7	14.2	7200 (496)	3600 (248)
3/8	-PBT-NT6	36.1	20.6	9.6	15.0	32.0	14.2	5600 (385)	2800 (192)
1/2	-PBT-NT8	39.6	25.4	11.9	19.8	39.6	19.1	5600 (385)	2800 (192)
3/4	-PBT-NT12	48.8	31.8	15.7	20.6	42.4	19.1	5100 (351)	2500 (172)
1	-PBT-NT16	48.5	42.9	22.4	25.4	49.3	23.9	5300 (365)	2600 (179)

ISO Tapered Threads

P-RT Size	Basic Ordering Number	Dimension, mm						Working Pressure psig (bar)	
		L	F	E	B	Lx	Bx	316 SS, Steel	Brass
1/16	-PBT-RT1	21.8	11.1	3.0	9.9	18.3	9.7	9200 (633)	4600 (316)
1/8	-PBT-RT2	26.4	12.7	4.8	10.4	22.1	9.7	6200 (427)	3100 (213)
1/4	-PBT-RT4	29.7	17.5	7.1	15.0	29.7	14.2	7200 (496)	3600 (248)
3/8	-PBT-RT6	36.1	20.6	9.6	15.0	32.0	14.2	5600 (385)	2800 (192)
1/2	-PBT-RT8	39.6	25.4	11.9	19.8	39.6	19.1	5600 (385)	2800 (192)
3/4	-PBT-RT12	48.8	31.8	15.7	20.6	42.4	19.1	5100 (351)	2500 (172)
1	-PBT-RT16	48.5	42.9	22.4	25.4	49.3	23.9	5300 (365)	2600 (179)

Female Tees

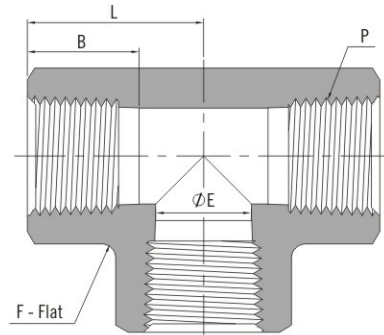

Female NPT Threads

P-NPT Size	Basic Ordering Number	Dimension, mm				Working Pressure psig (bar)	
		L	F	E	B	316 SS, Steel	Brass
1/16	-PT-NT1	21.8	11.1	4.8	9.9	6700 (460)	3300 (227)
1/8	-PT-NT2	26.4	12.7	8.6	10.4	6200 (427)	3100 (213)
1/4	-PT-NT4	29.7	17.5	11.4	15.0	7200 (496)	3600 (248)
3/8	-PT-NT6	36.1	20.6	15.0	15.0	5600 (385)	2800 (192)
1/2	-PT-NT8	39.6	25.4	18.5	19.8	5600 (385)	2800 (192)
3/4	-PT-NT12	48.8	31.8	23.9	20.6	5100 (351)	2500 (172)
1	-PT-NT16	48.5	42.9	29.7	25.4	6400 (440)	3200 (220)
1 1/4	-PT-NT20	59.8	50.8	37.2	25.4	3100 (213)	1600 (110)
1 1/2	-PT-NT24	65.0	63.5	43.3	27.7	5100 (351)	2500 (172)
Heavy-Wall Female NPT Threads							
1/4	-PT-NT4-10K	39.6	25.4	11.4	15.0	10000 (689)	/
1/2	-PT-NT8-10K	50.0	27.0	18.5	19.8	10000 (689)	/

Female ISO Tapered Threads

P-RT Size	Basic Ordering Number	Dimension, mm				Working Pressure psig (bar)	
		L	F	E	B	316 SS, Steel	Brass
1/16	-PT-RT1	21.8	11.1	4.8	9.9	6700 (460)	3300 (227)
1/8	-PT-RT2	26.4	12.7	8.6	10.4	6200 (427)	3100 (213)
1/4	-PT-RT4	29.7	17.5	11.2	15.0	7200 (496)	3600 (248)
3/8	-PT-RT6	36.1	20.6	14.7	15.0	5600 (385)	2800 (192)
1/2	-PT-RT8	39.6	25.4	18.3	19.8	5600 (385)	2800 (192)
3/4	-PT-RT12	48.8	31.8	23.9	20.6	5100 (351)	2500 (172)
1	-PT-RT16	48.5	42.9	29.7	25.4	6400 (440)	3200 (220)
1 1/4	-PT-RT20	59.8	50.8	37.2	25.4	3100 (213)	1600 (110)
1 1/2	-PT-RT24	65.0	63.5	43.3	27.7	5100 (351)	2500 (172)

Female Crosses

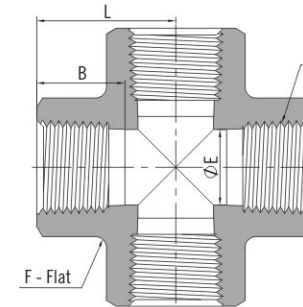

Female NPT Threads

P-NPT Size	Basic Ordering Number	Dimension, mm				Working Pressure psig (bar)	
		L	F	E	B	316 SS, Steel	Brass
1/16	-PCR-NT1	21.8	11.1	4.8	9.9	6700 (460)	3300 (227)
1/8	-PCR-NT2	26.4	12.7	8.6	10.4	6200 (427)	3100 (213)
1/4	-PCR-NT4	29.7	17.5	11.4	15.0	7200 (496)	3600 (248)
3/8	-PCR-NT6	36.1	20.6	15.0	15.0	5600 (385)	2800 (192)
1/2	-PCR-NT8	39.6	25.4	18.5	19.8	5600 (385)	2800 (192)
3/4	-PCR-NT12	48.8	31.8	23.9	20.6	5100 (351)	2500 (172)
1	-PCR-NT16	48.5	42.9	29.7	25.4	6400 (440)	3200 (220)

Female ISO Tapered Threads

P-RT Size	Basic Ordering Number	Dimension, mm				Working Pressure psig (bar)	
		L	F	E	B	316 SS, Steel	Brass
1/16	-PCR-RT1	21.8	11.1	4.8	9.9	6700 (460)	3300 (227)
1/8	-PCR-RT2	26.4	12.7	8.6	10.4	6200 (427)	3100 (213)
1/4	-PCR-RT4	29.7	17.5	11.4	15.0	7200 (496)	3600 (248)
3/8	-PCR-RT6	36.1	20.6	15.0	15.0	5600 (385)	2800 (192)
1/2	-PCR-RT8	39.6	25.4	18.5	19.8	5600 (385)	2800 (192)
3/4	-PCR-RT12	48.8	31.8	23.9	20.6	5100 (351)	2500 (172)
1	-PCR-RT16	48.5	42.9	29.7	25.4	6400 (440)	3200 (220)

Pipe to Pipe Unions

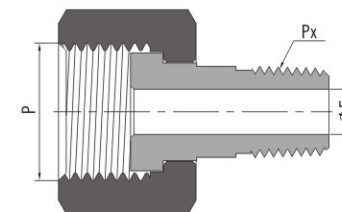

Metric Threads

P-Metric Thread Size	Px-NPT Size	Basic Ordering Number	Dimension, mm	Working Pressure psig (bar)
			E	
M20 x 1.5	1/8	-PUP-MM20-NT2	4.8	4500 (310)
M20 x 1.5	1/4	-PUP-MM20-NT4	7.1	4500 (310)

NPT Threads

Metric Threads

P-Metric Thread Size	Px-RT Size	Basic Ordering Number	Dimension, mm	Working Pressure psig (bar)
			E	
M20 x 1.5	1/8	-PUP-MM20-RT2	4.8	4500 (310)
M20 x 1.5	1/4	-PUP-MM20-RT4	7.1	4500 (310)

ISO Tapered Threads

ISO Parallel Threads

P-ISO Pipe Size	Px-NPT Size	Basic Ordering Number	Dimension, mm	Working Pressure psig (bar)
			E	
1/2	1/8	-PUP-MG8-NT2	4.8	4900 (337)
1/2	1/4	-PUP-MG8-NT4	7.1	4900 (337)

NPT Threads

Hand Tight Adapter Fittings

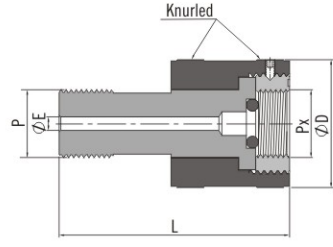

Metric Threads

P-Metric Thread Size	Px-Metric Thread Size	Basic Ordering Number	Dimension, mm			Working Pressure psig (bar) 316 SS, Steel
			L	D	E	
M14 x 1.5	M14 x 1.5	-HF-MM14	58	27.0	3.2	6100 (425)
M14 x 1.5	M20 x 1.5	-HF-MM14-MM20	58	37.5	3.2	5700 (393)
M20 x 1.5	M14 x 1.5	-HF-MM20-MM14	68	32.0	4.0	6100 (425)
M20 x 1.5	M20 x 1.5	-HF-MM20	68	37.5	4.0	5700 (393)
M20 x 1.5	M22 x 1.5	-HF-MM20-MM22	68	37.5	4.0	4000 (275)

Metric Threads

P-Metric Thread Size	Px-ISO Pipe Size	Basic Ordering Number	Dimension, mm			Working Pressure psig (bar) 316 SS, Steel
			L	D	E	
M20 x 1.5	1/4	-HF-MM20-MG4	68	32.0	3.2	6500 (447)
M20 x 1.5	3/8	-HF-MM20-MG6	68	32.0	3.6	4300 (297)
M20 x 1.5	1/2	-HF-MM20-MG8	68	37.5	4.0	4800 (334)

ISO Parallel Threads

ISO Parallel Threads

P-ISO Thread Size	Px-ISO Pipe Size	Basic Ordering Number	Dimension, mm			Working Pressure psig (bar) 316 SS, Steel
			L	D	E	
1/2	1/4	-HF-MG8-MG4	68	32.0	3.2	6500 (447)
1/2	3/8	-HF-MG8-MG6	68	32.0	3.6	4300 (297)
1/2	1/2	-HF-MG8	68	37.5	4.0	4800 (334)

Ordering Information

