

Features

- The hardened threads with smooth surface finishing avoid galling and help to extend the fitting service life.
- Radius junction design with elbows provides smooth flow path.
- Every fitting is stamped with size, material, and heat code.



Material

Material	Bar Stock	Forging	Designator
316 stainless steel	ASTM A276, ASME SA479, EN 1.4401	ASTM A182, ASME SA182, EN 1.4401	SS

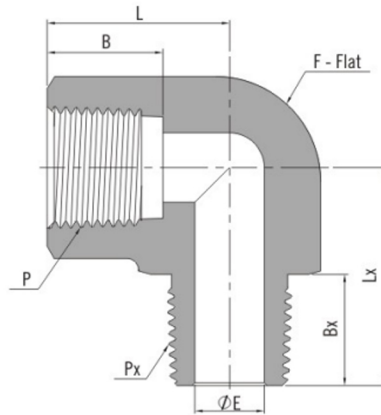

SIZE	CODE	THREAD (P)	L	F	B	E	Lx	Bx	WORKING PRESSURE
1/8	INS-SE02N	NPT	26.4	12.7	10.4	4.8	22.1	9.7	6200 PSI (426 BAR)
1/4	INS-SE04N	NPT	29.7	17.5	15	7.1	29.7	14.2	7200 PSI (496 BAR)
3/8	INS-SE06N	NPT	36.1	20.6	15	9.6	32	14.2	5600 PSI (385 BAR)
1/2	INS-SE08N	NPT	39.6	25.4	19.8	11.9	39.6	19.1	5600 PSI (385 BAR)
3/4	INS-SE12N	NPT	48.8	31.8	20.6	15.7	42.4	19.1	5100 PSI (351 BAR)
1	INS-SE16N	NPT	48.5	42.9	25.4	22.4	49.3	23.9	5300 PSI (365 BAR)

**** DIMENSIONS SUBJECT TO CHANGE - PLEASE CONTACT US IF CRITICAL ****



5 STAR ★★★★★
CUSTOMER SERVICE



SAME DAY DISPATCH -
ORDERS PLACED BEFORE 4:30PM



WEALTH OF
INDUSTRY KNOWLEDGE



ONE OF THE LARGEST
STOCKISTS IN THE UK