

### GATE VALVE NPT

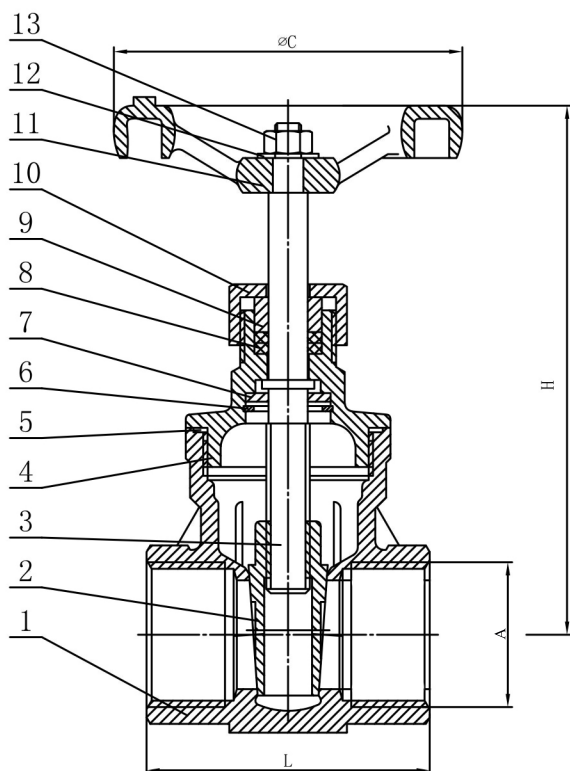

Main Technical Parameter			
Normal pressure		200	PSi
Test pressure	Shell test pressure	3.8	MPa
	Tightness test	2.8	
	Gas-Tightness test	0.6	
Max working temperature		-20~180	°C
Applicable medium: water, gas, oil, acid			

#### PRESSURE TEMPERATURE RATINGS

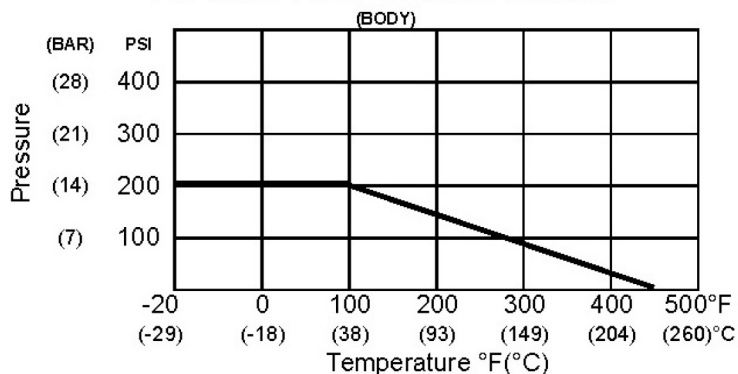

No.	Parts name	Material	No.	Parts name	Material
1	Disc	ASTM A276 316	9	Gland	ASTM A276 304
2	Body	ASTM A351 CF8M	10	Cap Nut	ASTM A351 CF8M
3	Stem	ASTM A276 316	11	Handwheel	QT400-18
4	Cap	ASTM A351 CF8M	12	Spring washer	ASTM A193-B8
5	Gasket	PTFE	13	Handle nut	ASTM A194-B8M
6	Stop Gasket	ASTM A276 304	14		
7	Washer	ASTM A276 304	15		
8	V-Ring Packing	PTFE	16		

Sizes : 3/8" to 2"  
 Working pressure : 200 PSI (14 bar)  
 Non rising stem  
 Body : CF8M 316  
 Solid wedge disc  
 Threaded ends : ANSI B2.1 NPT  
 For chemical and industrial applications  
 Inspection test to API 598

SIZE NPT	PART No	A	L	H	C	CV FACTOR	Kg
3/8	GV06N	12	55	95	70	16	0.30
1/2	GV08N	16	55	95	70	19	0.42
3/4	GV12N	20	60	102	70	37	0.56
1	GV16N	26	65	115	80	64	0.75
1 1/4	GV20N	32	75	130	80	103	1.00
1 1/2	GV24N	40	80	145	100	143	1.50
2	GV32N	50	95	170	100	360	1.95

\*\*DIMENSIONS SUBJECT TO CHANGE, PLEASE CONTACT US IF CRITICAL\*\*